

Filter pumping system

Technical data	
Dimensions (LxTxH)	400 x 650 x 750/900 mm
Basket size	300 x 320 x 155 mm
Basket capacity	2.5 kg
Total capacity	17.0-20.5 Liter
Connected load	16.0 kW
Voltage	3-phase 400 V AC
Fuse	3 x 25 A
Number of basins	1
Number of baskets	1
Frying output (chilled food)	50 kg/h
Frying output (frozen food)	38 kg/h
Thermostat control range	50-180/190 C°
Sensible heat dissipation	1.44 kW
Latent heat dissipation	11.20 kW
Steam output	16.48 kg/h
Insulation value	0.18 m²K/W (R-value)
Water protection	IPX4
Automatic basket lift	optional
Integrated oil/fat pump	optional
Mobile design	optional
Door hinge	left/right

Incl. cable 2m, WITHOUT plug

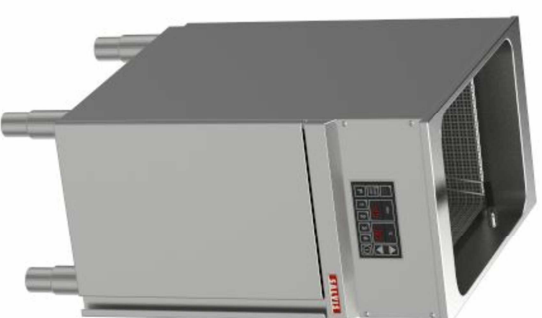
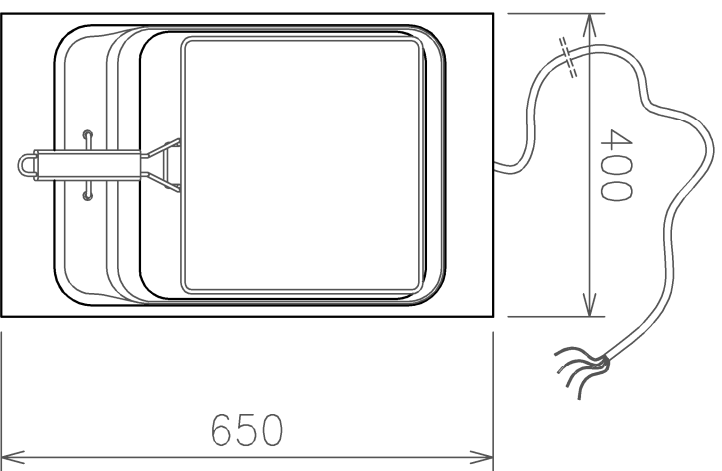

with pump



with lift



with pump and lift



Technical modifications reserved

Freestanding Deep Fat Fryers FrylineEVO

Freestanding model incl. frying basket

Type: SFR-EVO 41

Drawing no: SFR-EVO 41

Index 00

Format	Scale	Index	Date	Draftsman
A3	1:10	00	12.12.2024	NeV

SALVIS AG
 CH- 4665 Oftringen
 Tel. +41 62 788 18 18
 www.salvis.ch
 smart cooking



We are the owners of the copy-right of this drawing.
 Any use or partial use which has not been authorized by us is forbidden in accordance with current legislation. This includes making unauthorized copies of the drawing or letting others make use of it or divulging information from it to third parties.
 Violation of these rules are legally punishable and make the offender liable to the payment of damages.