



**NEW & HOT**

# REFINED.

## Deep Fat Fryers

### Salvis FrylineEVO



Salvis is a Swiss company that is over 100 years old. We build high-quality hobs and appliances for professional kitchens. Salvis stands for energy-saving, easy-to-use products that deliver excellent baking and cooking results.

## Accomplished culinary systems for pros

Performance and safety are the focus of Salvis modern culinary systems. The Salvis Fryline deep fat fryers offer an impressively functional design including a new **high-performance tubular heaters with 20% increased surface** and electronic temperature sensors.

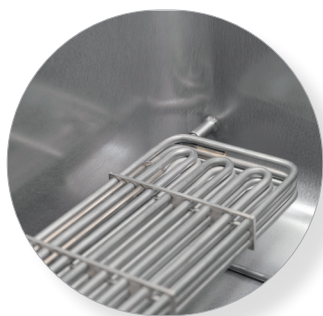

### Electronic control

Temperature sensor sensitivity  $\pm 1^\circ\text{C}$ ; precise temperature control with **electronic temperature sensors**, optimum frying results and gentle fat handling.



### Basin and oil /fat tank

Smooth, **deep-drawn, seamlessly welded-in tank** using radial construction for effortless cleaning.



### Efficient heating system

Swivelling radiator integrated in the basin. **Radiator with 20% more surface** for an optimum energy transfer



### Cleaning & pump system

Removable inlet tube, with **heat resistant grip for filling the cleaned frying basin**; clipping to the basin rim possible.



### Complies with the acrylamide regulation

- High performance heating elements allows frying under  $170^\circ\text{C}$
- Including electronic Timer with signal
- Automatic quantity adjustment - AQA



### Safety for quality and application

- Gentle oil heating programme
- Standardised timer functions
- Four fixed temperature and time programmes



### Versatile and economical

- Optional basket lift mechanism
- Dual oil/fat filter system
- Optional mobile version: feet at the front, rollers at the back (not for model SFR 21)



## The Salvis oil filter pump systems.

Filtering at the touch of a button.

Simple, ecological oil care.

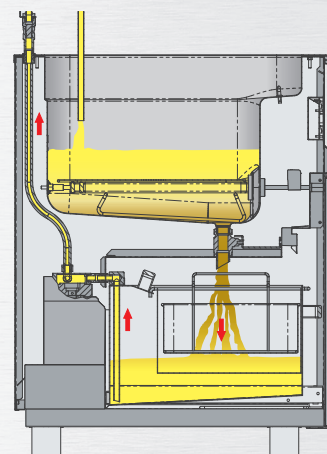



## Salvis Fryline deep fat fryers

All models are available as **freestanding or built-in models** with added operating convenience. Depending on requirements, optional equipment variants such as the oil filter pump system or an automatic basket lifting device can be added as required. A mobile version is available.

- 

**Automatic quantity adjustment (AQA).** The electronic system adjusts cooking times automatically depending on the volume of food to fry.
- 

**20% larger heating surface. More heat, less energy!**  
Greater efficiency for more happy guests!
- 

**Programmable oil usage time** for optimum control of the oil.
- 

**Electronic control** via a membrane keypad with a simple and clearly laid-out user interface.
- 

**Energy-saving mode** - automatic temperature reduction after 30 minutes without operation.
- 

**20 predefined product keys.** Guaranteed success in the system catering.



Salvis FrylineEVO, SFR 21  
Single basin fryer, 200 mm



Salvis FrylineEVO, model SFR 31  
Single basin fryer, 300 mm



Salvis FrylineEVO, model SFR 41  
Single basin fryer, 400 mm



Salvis FrylineEVO, model SFR 42  
Double basin fryer, 400 mm  
Image with options



**Smart cooking** means cooking profitably and economically with cook-and-chill production, using Salvis GreenVAC vacuum technology. **Smart cooking** is the perfect recipe for happy hosts and guests.

## TECHNICAL DATA IN BRIEF.

Technical data		SFR-EVO 21	SFR-EVO 31	SFR-EVO 41	SFR-EVO 42
Dimensions (L × D × H)	mm	200 × 650 × 750/900	300 × 650 × 750/900	400 × 650 × 750/900	400 × 650 × 750/900
Basket size	mm	140 × 320 × 155	220 × 320 × 155	300 × 320 × 155	2 × 140 × 320 × 155
Basket capacity	kg	1,25	1.8	2,5	2 × 1,25
Total capacity	litres	7.5–9.0	12.5–14.5	17.0–20.5	2 × 7.5–2 × 9.0
Connected load	kW	8.0	11.0	16.0	2 × 8.0
Voltage		3-phase 400 V AC	3-phase 400 V AC	3-phase 400 V AC	3-phase 400 V AC
Fuse	A	3 × 16	3 × 16	3 × 25	2 × (3 × 16)
Number of basins		1	1	1	2
Number of baskets		1	1	1	2
Frying output chilled food - 170°C	kg/h	25	36	50	50
Frying output frozen food - 170°C	kg/h	20	27	38	38
Temperature control range	°C	50–170/180	50–170/180	50–170/180	50–170/180
Automatic basket lift		optional	optional	optional	optional
Integrated oil/fat pump		optional	optional	optional	optional
Mobile design		not available	optional	optional	optional
Door hinge		left/right	left/right	left/right	left/right

Accessories and special voltages available on request. Wiring diagrams and technical details are included in the operating instructions. Subject to changes in power, dimensions and construction.

### SALVIS AG

Nordstrasse 15  
CH-4665 Oftringen  
[www.salvis.ch](http://www.salvis.ch)

Telephone +41 62 788 18 18  
E-Mail [info@salvis.ch](mailto:info@salvis.ch)

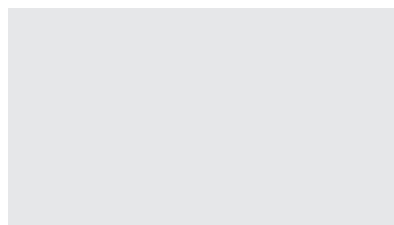

10/2024 - 22000077 -

