

SALVIS Combi-Steamer

CUCINA^{EVO} Easy
CUCINA^{EVO} Pro

623 611 1011 T

611 621 1011 1021 QT

2011 2021 QT

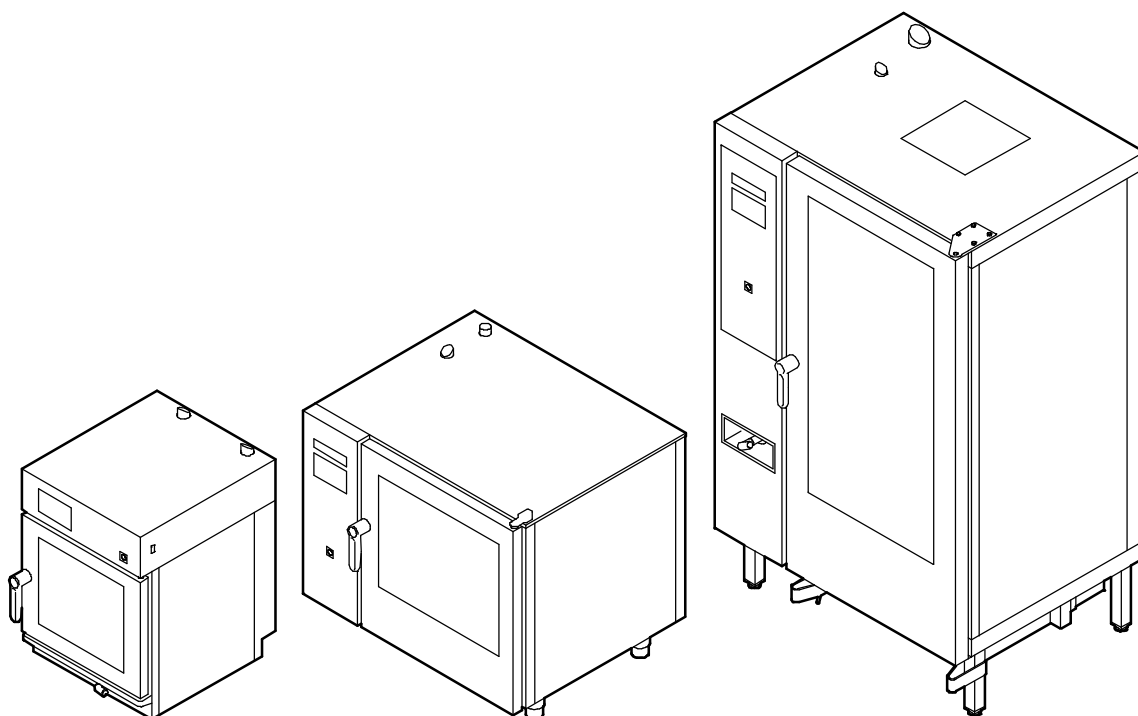

Operation instructions

en: Translation of the original operating instructions

Please read the installation and operating instructions before installing and starting to use the appliance!

1.	User information	4
1.1	Information about the instructions for the appliance	4
1.2	Symbols in front of the text	4
1.3	Warning signs, danger symbols and information symbols	4
1.4	Use as intended	5
1.5	Misuses	5
2.	Safety instructions	5
3.	Description of the appliance	8
3.1	Description of the function components, Types 623, 621, 611, 1011, 1021	8
3.2	Description of the functional components, Type 2011, 2021	9
3.3	Opening the cooking chamber door	10
3.4	Using the pull-out shower with automatic retraction	10
3.5	Function of the condensate cover (optional)	10
4.	Familiarise yourself with the operating and display panel.	11
4.1	Overview of control versions	11
4.2	Notes on using the touch-screen	12
4.3	Mode settings "Steam, Hot Air Steam, Hot Air"	13
5.	Commissioning	14
5.1	Getting ready for use	14
5.1.1	Inserting the air filter	14
5.1.2	Screwing on the water manifold (optional automatic cleaning system)	14
5.1.3	Inserting the air baffle	14
5.1.4	Inserting the grease filter (optional)	15
5.1.5	Inserting the removable racks	16
5.2	Inserting/removing removable racks/rack trolleys (option)	17
5.3	Switching on the device	18
5.4	Prevent smoke development with greasy foods	18
5.5	Loading	19
5.5.1	Maximum permissible loading weight	19
5.5.2	Using the core temperature sensor	19
5.5.3	Using the Sous-Vide sensor (option)	20
5.6	Starting / ending the cooking process	21
5.6.1	Starting the cooking process	21
5.6.2	End of the cooking process	22
5.6.3	Removing the containers	22
5.7	Cooling of the cooking chamber with cooking chamber door open	22
6.	Using operating modes, cooking programs	24
6.1	Setting the cooking process - manual settings	24
6.2	Cooking steps to add / combinations	28
6.3	Using vitalising	31
6.4	Cooking process application	32
6.5	Special programs application	33
6.6	Working using slide-in times	34
6.7	Using combi-cooking	36
6.8	Applying the SmartCooking program	38
6.9	Using cooking programs from the cookbook	40
6.10	Working with categories (menu groups)	42
6.11	Working with favourites (preferred products)	43

7.	Creating, changing, deleting products in the cookbook	44
7.1	Creating, saving and assigning products	44
7.2	Changing the settings of products in the cookbook	48
7.3	Deleting a product from the cookbook	49
7.4	Creating and deleting a category	50
7.4.1	Creating a category	50
7.4.2	Delete category with products	51
8.	Using baking	54
9.	Displaying HACCP protocols	56
9.1	Reading HACCP protocols on a USB stick	57
10.	Setup of the control and user interface	58
11.	Exporting and importing data	69
11.1	Requirements for USB data storage media (USB flash drive)	70
11.2	Data export: information about the data structure on the USB stick	71
11.3	Data import: information about the "Replace/Add" option	72
11.4	Exporting data - example: saving data	73
11.5	Importing data - example: replacing a cookbook/cookbooks	74
12.	Completion of operation	75
13.	Cleaning and Care	75
13.1	Notes on stainless steel (risk of corrosion!)	75
13.1.1	Secondary cleaning after completion of automatic cleaning (liquid/powder cleaner)	75
13.2	Notes on cleaning	76
13.3	Preparing the appliance for cleaning of the cooking chamber	76
13.3.1	Cleaning the water manifold	77
13.3.2	Cleaning the outlet screen in the cooking chamber drain	77
13.3.3	Using the sealing plate Type 2011/2021	77
13.4	Cleaning the cooking chamber - without automatic cleaning system	78
13.5	Cleaning the cooking chamber - automatically, with powdered cleaner (optional) .	80
13.5.1	Dosing quantities for powdered cleaner:	80
13.5.2	Starting the automatic cleaning process (powdered cleaner)	81
13.6	Cleaning the cooking chamber - automatically, with liquid cleaner (optional)	83
13.6.1	Connecting or replacing the cleaning agent and rinse-aid canisters	83
13.6.2	Filling the suction hoses with cleaning agent and rinse-aid.	84
13.6.3	Starting the automatic cleaning process (liquid cleaner)	85
13.7	After completion of automatic cleaning	87
13.7.1	Cleaning the glazing, cooking chamber door and seal	88
13.7.2	Cleaning the grease filter (optional)	88
13.7.3	Cleaning the cooking chamber behind the air baffle.	89
13.7.4	Clean air filter	90
13.7.5	Clean stainless steel surfaces	90
13.7.6	Cleaning the control/display panel and the key "On/Off"	91
13.8	Decalcifying the cooking chamber	91
13.9	Cancelling automatic cleaning	91
13.10	Cleaning of the condensate cover, air filter (optional)	92
14.	Errors and remedies	92
15.	Service	94
16.	Disposal of end-of-life appliances	94
17.	Declaration of Conformity	95
18.	Software declaration	95

1. User information

1.1 Information about the instructions for the appliance

These operating instructions contain important information on the safety, operation, settings and cleaning of the appliance.

Refer to the installation instructions for information on the setup and installation of the unit.

Read the operating and installation instructions carefully before starting to use the appliance.

The owner of the appliance must ensure that the instructions are accessible to the staff employed to operate the appliance.

Always keep the documents accompanying the appliance close to hand and pass these on with the appliance to any new owner.

1.2 Symbols in front of the text

 You are requested to carry out an action.

- Enumeration and listing
- Notes, operational sequences

Text without symbols: Descriptions or explanations after a heading.

Text in italics - refers to another chapter

1.3 Warning signs, danger symbols and information symbols



DANGER! Electrical voltage! Risk of electric shock that may result in serious injury or death!



WARNING! Caustic substances! Risk of chemical burns with possible serious injury! Wear protective clothing, protective gloves and safety goggles!



WARNING! Risk of injury! Warning of possible injuries through escaping hot steam with caustic cleaning agents! Do not open the cooking chamber door during the automatic cleaning process!



CAUTION! Risk of injury, risk of damage! Warning of possible injury, a health risk or damage to property! Wear protective clothing, protective gloves and safety goggles! Exercise appropriate caution!



CAUTION! Warning of hot objects and possible injury by burns! Serious burns are possible in the event of a fire! Wear protective clothing, protective gloves and safety goggles! Exercise appropriate caution!



WARNING! Scalding hazard! Containers with liquids or products to be boiled, becoming liquid during the cooking process, may only be pushed into the slot that can be easily viewed by the operating personnel.



Information! Notes containing particularly useful information and tips.

1.4 Use as intended

- The appliance is for commercial use and may only be operated
 - by trained personnel,
 - if the appliance is supervised,
 - for the purpose designated in the operating instructions.
- The appliance may only be used for the preparation of foodstuffs. E. g. for the steaming, stewing, frying, grilling, baking, defrosting, warming and keeping warm of meat, fish, potatoes, vegetables, confection of pastries, filled stuffed pasta and baked goods.
- The user alone is responsible for damage caused by use contrary to the intended use.

1.5 Misuses

- The appliance may not be used for the heating, drying and storage of objects and not for the melting of materials!
- No flammable and ignitable objects may be placed into the cooking chamber.
- The appliance may not be operated outdoors and not without water hook-up.
- The appliance may not be used
 - by children,
 - persons with restricted physical, sensory or mental abilities and
 - untrained personnel.

2. Safety instructions

Use



- Note the safety information in the operating and installation instructions.
- Do not use the appliance as a storage or work surface.
- Openings for supply and exhaust air of the cooking chamber and the control panel must not be covered.
- Check before use whether the cooking chamber still contains residues from cleaning agents and rinse-aid.
- An automatic rinse process must be started if the automatic cleaning of the cooking chamber was interrupted (e.g. power failure). This prevents contamination of the food items with cleaning agent residues or damage to chambers.
- Packaged products may only be cooked in heat-resistant containers approved for foodstuff areas.
- No foodstuffs may be heated in sealed cans or tinned food packaging.
- The product to be cooked may not touch the cooking chamber, grease filter or air baffle.
- Observe, e.g. for function of the start time selection: If uncooled or unheated food is in the cooking chamber, e.g. bacteria can very quickly multiply!
- Observe the information about "Cleaning" in these instructions, *see from Page 75 in Chapter 13*.
- Please observe the stipulations and rules of the professional associations!
- If you cannot rectify malfunctions using page 92, Chapter 14. "Troubleshooting and Remedies", switch off the appliance, disconnect from power, shut off the water tap and notify authorised Customer Service.
- For appliances on wheels, the manoeuvrability of the appliance must be restricted to the extent that any damage to the supply and disposal lines is prevented. Secure the appliance again with the safety chain after transportation (see installation instructions).

WARNING! Risk of injury

- During operation there is a risk of burns from
 - hot surfaces,
 - hot cooked products,
 - hot removable racks,
 - hot rack trolleys and
 - hot escaping steam when opening the cooking chamber door.

- Scalding hazard! Containers with liquids or products to be boiled, becoming liquid during the cooking process, may only be pushed into the slot that can be easily viewed by the operating personnel. Slipping may cause scalding when removing liquid cooked products! A supplied safety sticker must be affixed at an appropriate location. Refer to the description in the installation instructions regarding affixing the safety sticker.

- The appliance may no longer be operated when the glazing in the door, on the cooking chamber lighting or on the control panel is damaged! The food must be disposed of in the event of glass breakage during the cooking process!

- Scalding hazard! Risk of damage Do not use the pull-out shower to spray into the hot cooking chamber.

- Slip hazard! Remove any water or food that has been spilt on the floor immediately.

- Note weight of filled Gastronorm containers! Take care of your back when working!

- Danger of slipping! Remove water or food that has been spilt on the floor immediately.

- The appliance must not be operated if the mains cable/mains plug is damaged. Have the mains cable/ mains plug replaced by authorised Customer Service or a qualified electrician, otherwise there is a risk of electric shock!

- The pull-out shower may only be used to rinse out the cooled cooking chamber.

- Risk of injury! Remove the air baffle only after the ventilator wheel has come to a stop and the appliance is switched off. Do not slow down the ventilator by hand.

- If the shower head or the hose is defective, you must notify the authorised customer service.

- Contact the authorised customer service if the automatic cleaning system is defective.

- Obtain instructions as user of the appliances as to where to find the building's circuit breaker for the appliances to be operated. This allows you shutting down the appliance without hazard in the event of fire or damage.

- Rack trolleys/transport carts, as well as appliances on wheels, may tip over when transported across slanted surfaces or thresholds!

- For appliances on castors or on mobile frames: Observe the installation instructions! Secure the appliance/frame against rolling away during operation (engage the brake)! Do not move the appliance during operation! Before moving the appliance, remove any containers/food, switch off the on-site main switch, disconnect the mains plug, shut off the water supply tap, remove the water drain pipe and the water feed hose, roll up all connecting cables and secure against falling, release the brake on the castors. Caution – risk of tipping: Move the appliance/frame carefully!

**WARNING! Danger of chemical burns**

- Cleaning agents are caustic! Wear suitable protective clothing, protective gloves and safety goggles when handling cleaning agents!



- The cooking chamber door must not be opened while automatic cleaning is in progress. Caustic vapour and cleaning solution may escape!

CAUTION! Risk of damage

- Risk of splinters! Do not hit the glass panes of the appliance with objects such as the GN sheets or grilles. Do not drive against the glazing with rack trolleys, serving carts, etc.
- Do not spray or clean the appliance with water hoses, high pressure cleaners, high pressure steam cleaners or steam cleaners!
- Do not spray foam cleaner on front panels and appliance panels. The foam cleaner gets into the smallest of cracks and destroys the electrical and electronic systems.
- If the appliance has not been used for some time, have an authorised customer service agent check it for correct operation.

Determination and assessment of hazards in accordance with the German Health and Safety at Work Act

- According to the German Health and Safety at Work Act, the employer must assess what hazards are present for those occupied in the work and what health and safety measures are necessary. Observe the information supplied by the employers' liability insurance association for commercial kitchens.
- The employer must specify and provide the personal protective equipment.

3. Description of the appliance



Operating principle

- The heat in the cooking chamber is supplied via electrically heated heating elements.
- According to the different operating modes and settings by the user, a defined volume of water is evaporated via the heating elements.
- The ventilator distributes the hot and moist air in the cooking chamber.
- Settings are made via the touch-screen.
- The control system ensures the automatic sequence of the cooking processes.

3.1 Description of the function components, Types 623, 621, 611, 1011, 1021

Types 623, 611, 1011 T

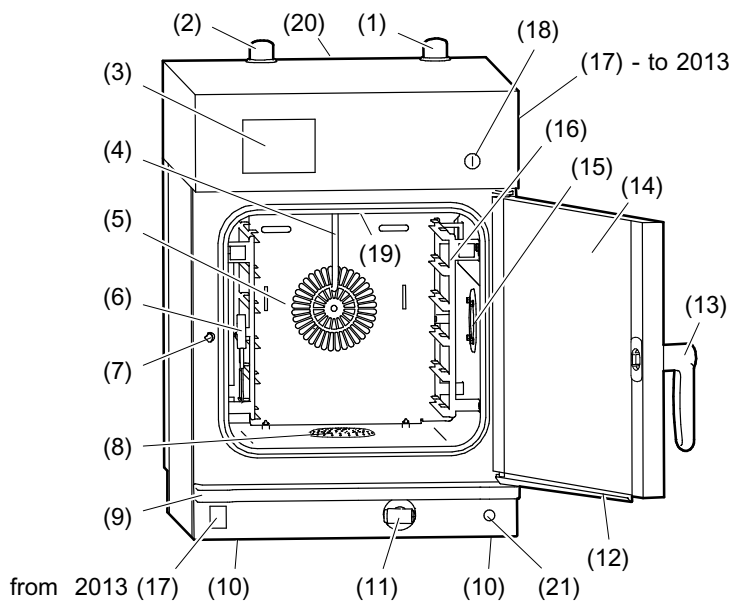

- (1) Cooking chamber supply air
- (2) Exhaust air, vapour
- (3) Display and control panel (Touch-screen)
- (4) Water supply pipe
- (5) Air baffle
- (6) 4-point core temperature sensor
- (7) Door catch
- (8) Outlet screen
- (9) Drip pan housing
- (10) Adjustable feet
- (11) Pull-out spray (optional)
- (12) Door condensate collecting groove
- (13) Door handle

Types 611, 621, 1011, 1021 QT

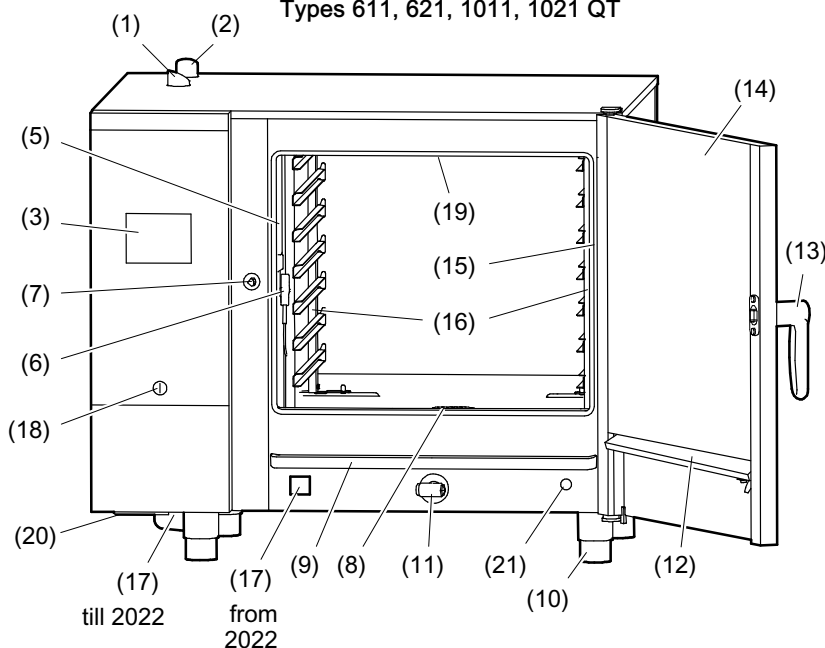

- (14) Cooking chamber door with locking levels
- (15) Cooking chamber lighting
- (16) Hook the removable rack
- (17) USB connection (option)
- (18) Main appliance On/Off switch
- (19) Water manifold for automatic cleaning system (optional)
- (20) Air filter - supply air control
- (21) Connection Sous-Vide sensor (option)

3.2 Description of the functional components, Type 2011, 2021

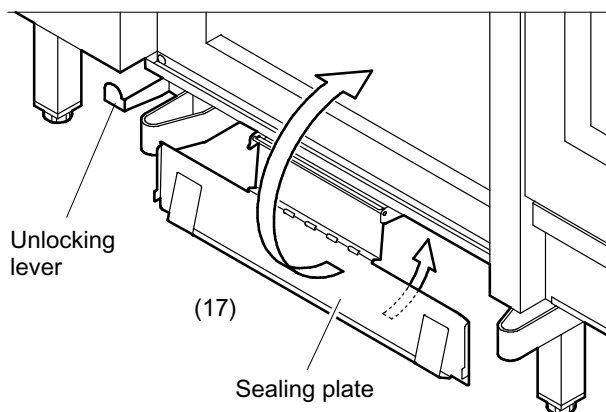
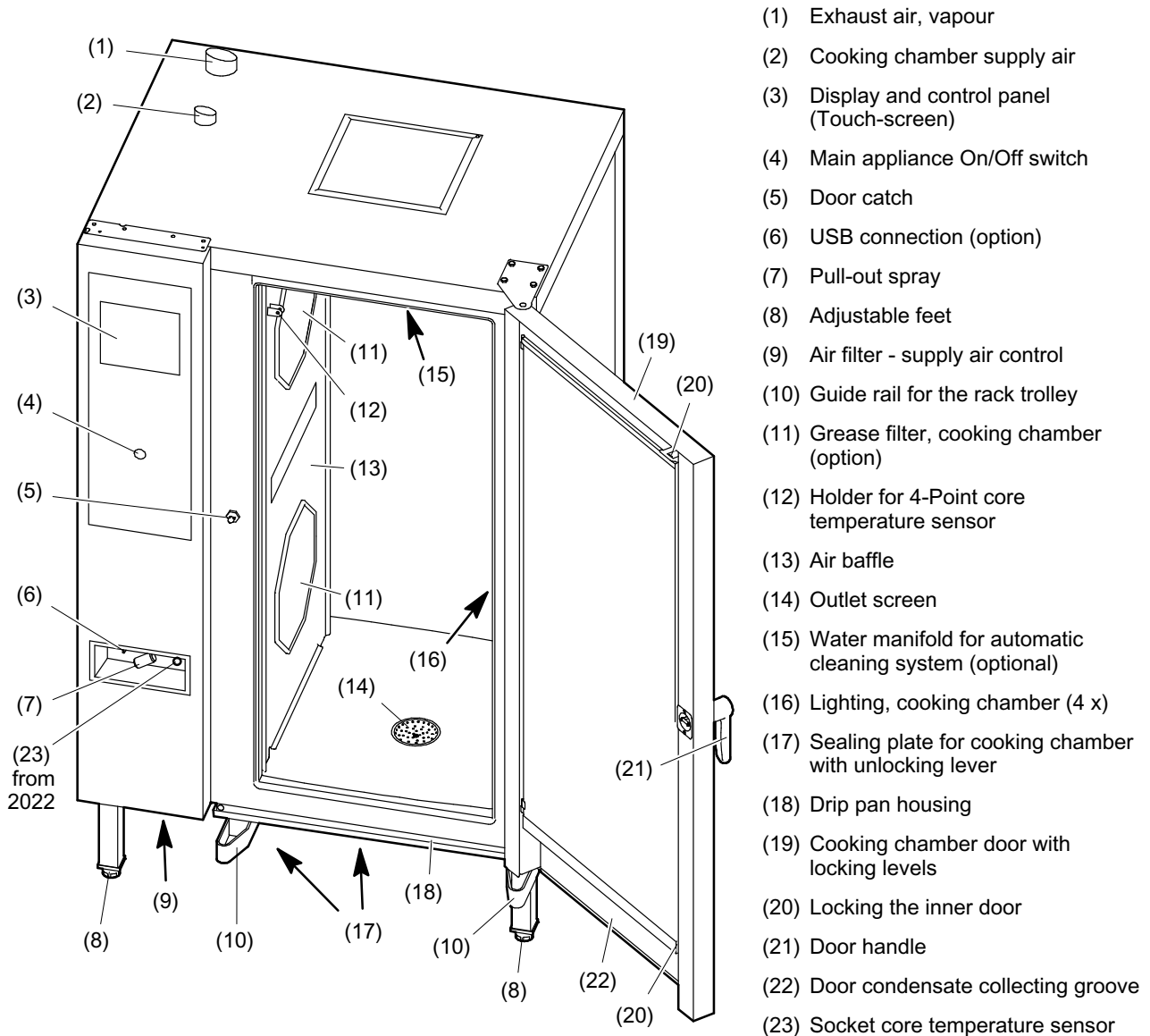

⚠ CAUTION! Risk of bruising on the feet! Before unlocking or swivelling the sealing plate downwards, remove the sealing plate from the swivel area.

The sealing plate is required in order to completely close the cooking chamber,

- if the appliance is operated without rack trolley (e.g. for preheating),
- for automatic cleaning without rack trolley pushed in.

Using the sealing plate, refer to Page 77 Chapter 13.3.3

3.3 Opening the cooking chamber door



WARNING! Scalding hazard! Open carefully! Allow steam and hot air to escape to prevent a hazard to any person!

Operating the door handle

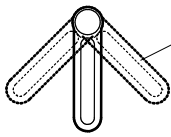

Door handle
The cooking chamber door can be unlocked by turning the door handle in both directions.

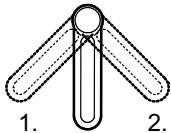

Two-stage door lock
E.g. on devices with condenser hood:

1. 1. Turn door handle to the left.
 - Let the steam escape through the condenser hood.
2. 2. Turn door handle to the right.

- Opening the cooking chamber door during a cooking process shuts off the ventilator and heater. The cooking process continues automatically after closing the door.
- Risk of splinters! Do not hit the glass panes of the appliance with objects such as the GN sheets or grilles. Do not drive against the glazing with rack trolleys, serving carts, etc.
- Note on condensate water leaking from under the appliance: When working at high temperatures and if the cooking chamber door is shut immediately after opening, condensate water may leak out of the safety overflow (e.g. not enough time allowed for pressure compensation).

3.4 Using the pull-out shower with automatic retraction

- Use the pull-out shower only in the cooking chamber.
- Do not use the pull-out shower in the heated cooking chamber because of
 - risk of injury from hot steam or
 - risk of damage of the cooking chamber and the glazing!
- The pull-out shower may not be used to cool down the cooking chamber!

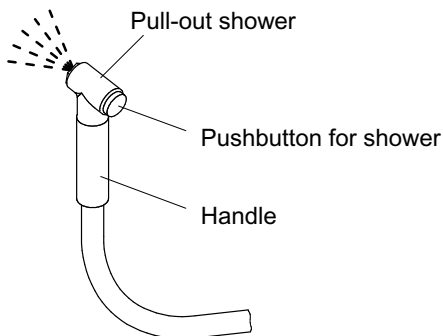

Operation

- The pull-out shower engages at several positions.
- The pull-out shower can be retracted between the locking points.
- The locking points can be heard and felt.
- The water supply is activated when the cooking chamber door is open.
- Guide the pull-out shower back into the appliance by hand during retraction. Do not allow so snap back!
- After use, the spray nozzle hose has to be fully retracted into the appliance, otherwise there is a risk of damaging the spray nozzle or the cooking chamber door.

3.5 Function of the condensate cover (optional)

- The condensate cover is controlled automatically.
- The fan is activated
 - when humidity and temperature have increased in the exhaust air.
 - in four output stages, depending on the volume of humidity and the temperature reached in the exhaust air.
 - at the highest output stage at the end of the cooking process and when the door of the cooking chamber is opened.
 - at low speed if the door of the cooking chamber remains open for a prolonged period of time (time-controlled).

4. Familiarise yourself with the operating and display panel.

4.1 Overview of control versions

After the control system is switched on and has powered up different user interfaces appear according to the appliance features.

Control system operating features "Easy"

With four modes of operation:

- Steaming
- Combi-steaming
- Hot air
- Vitalising
- Cooking method

Using the operating modes, see from Page 24 Chapter 6.1 to Chapter 6.4

Example display

The user can adapt the "Input and display area" according to the operational circumstances.

Changing the views in the "Input and display area", see page 58 section 10. fig. 12 and 13

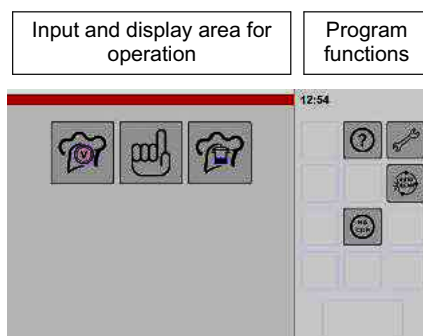

Display HACCP data, refer to Page 56 Chapter 9.

Special equipment

If auxiliary functions are purchased and installed, for the description of these, see from Page 33 Chapter 6.5

Baking, refer to Page 54 Chapter 8.

Control system operating features "Pro"

The control system permits many different operating versions:

- Cookbook program list
- Cookbook with pictogram
- Own favourites list (preferred products)
- Nine preset cooking methods
- Categories as list or pictogram (products divided into groups)
- 20 cooking steps can be combined
- Special programs
- User-selectable allocations and
- manual setting

Using the operating modes, see from Page 24 Chapter 6.

Example display

The user can adapt the "Input and display area" according to the operational circumstances.

Changing the views in the "Input and display area", see page 58 section 10. fig. 12 and 13

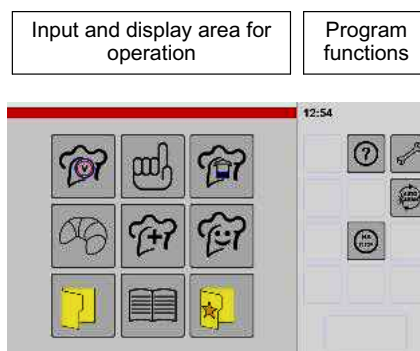

Display and read HACCP data, refer to Page 56 Chapter 9.

Special equipment

E.g. baking, refer to Page 54 Chapter 8.

4.2 Notes on using the touch-screen

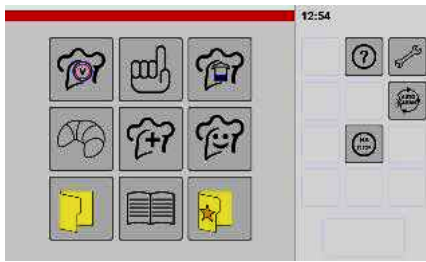
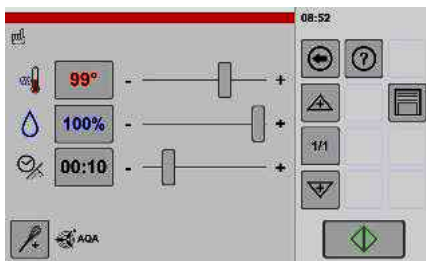







Fig.: Control system Pro

Operating and display panel: Touch-screen

- The control system of the appliance is operated via the touch-screen.
- The touch-screen may be operated only with the fingers. Brief tapping is sufficient.
- Do not operate the operating panel with ballpoint pens or other objects.
- The layout and number of symbols in the "Input and display area" can be customised to the user requirements. Refer to Page 58 section 10. figure 12 and 13.
- If there is not input for a certain period, the brightness of the screen is reduced. Tapping on it increased the brightness.



Easy operation

- The control system is easy to operate. Tapping on the symbols guides you to the next setting option. Switch through the menus for practice. You can always return to the previous menu with the back key .
- By briefly tapping and holding the back key  the display changes to the "home"  symbol. The start screen appears after releasing the key.
- The help function provides you with additional information in the respective menus. An info text is shown when you tap the help key . Close the info text with the exit key .

Auxiliary function disabled or enabled

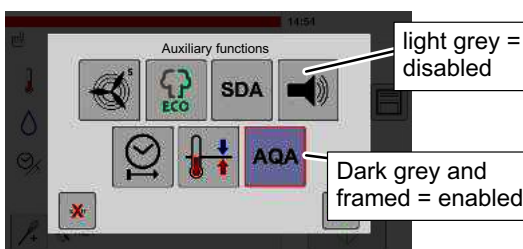

Differences light grey - dark grey

Depending on the various functions key symbols are shown light or dark grey and framed.

Auxiliary function enabled or disabled

This auxiliary function can be enabled or disabled by tapping the key.

- Light grey = auxiliary function disabled
- Dark grey = auxiliary function enabled

Display of possible functions



Display of possible functions

- Light grey = selection not possible
- Dark grey = selection possible

4.3 Mode settings “Steam, Hot Air Steam, Hot Air”





“Modes” window

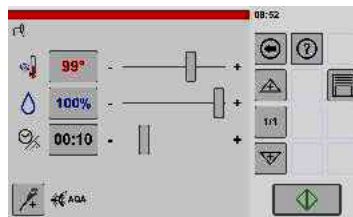



“Settings” window







Steaming

-  Temperature range 30 - 130 °C
-  Moisturization 100% (not adjustable)
-  Core temperature range 0 - 99 °C
-  The adjustable fan speed is limited:
3 - 4 - 5



Hot air steaming

-  Temperature range 30 - 250 °C
-  Moisturization 0 - 100%
-  Core temperature range 0 - 99 °C

Hot air

-  Temperature range 30 - 250 °C
-  **No moisture can be added:**
This setting influences maintaining the cooked product's own moisture.
-  The supply air flap opens or closes depending on the setting.
-  Air flap position in increments of 20:
0, 20, 40, 60, 80, 100%
 - 0% = Supply air flap open - cooking chamber is dehumidified
 - 100% = Supply air flap closed - own moisture of the food being cooked remains in the cooking chamber
-  Core temperature range 0 - 99 °C

Regeneration

-  Temperature range 30 - 250 °C
-  Moisturization 0 - 100%
-  Core temperature range 0 - 99 °C

Special programs

For applications, refer to page 33 chapter 6.5

5. Commissioning

- ☞ Before using the appliance for the first time, clean with a cleaning product that dissolves grease.
For cleaning, see page 75, Chapter 13.

Only for appliances with automatic cleaning system, not for Types 2011:

- ☞ Before initial commissioning or after extended operating breaks, fill approx. 5 litres of water into the cooking chamber drain (overheating protection/odour trap).

5.1 Getting ready for use

- ☞ Check whether the cooking chamber is clean and free of cleaning agent residues.

5.1.1 Inserting the air filter

- ☞ Set the air filter in the guide rails and push against the stop.

Type 623 T,
611 T,
1011 T

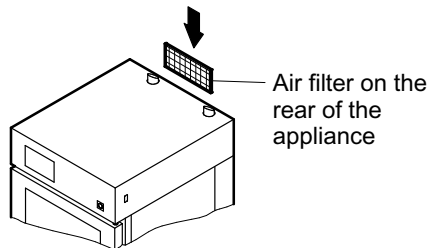

Type 611, 621QT,
1011, 1021QT,
2011, 2021QT

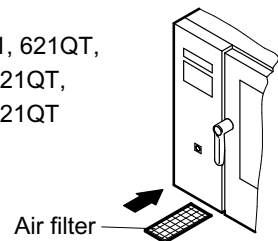

5.1.2 Screwing on the water manifold (optional automatic cleaning system)

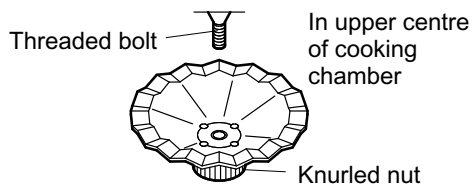

- Only for appliances with automatic cleaning system!

- ☞ Insert water manifold up in the cooking chamber and fasten with by hand with knurled nut.

5.1.3 Inserting the air baffle



- The device may not be operated without air baffle!
- The device must be switched off during installation.
- The air baffle may not be dismantled or mounted while the ventilator is still running!

Air baffle (at rear of cooking chamber)

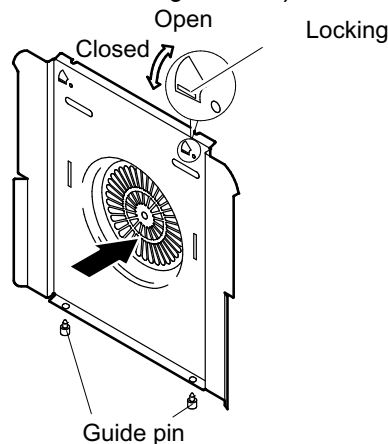

Inserting the air baffle type 623T, 611T, 1011T

- ☞ Air baffle
 - insert at the bottom into the two guide pins,
 - lean against the holder at the top,
 - use a screwdriver to close both locks by turning them to the left.
- Open/close locking mechanism:
 - Open by turning to the right,
 - Close by turning to the left.

Air baffle (at left in cooking chamber)

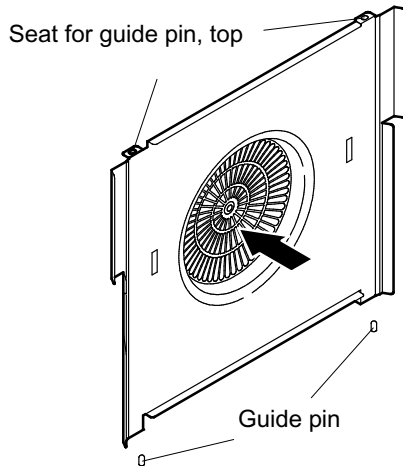

Inserting the air baffle type 611, 621QT, 1011, 1021QT

☞ Insert air baffle into the guide pins:

1. Insert at top
2. Lift air baffle
3. Insert at bottom

Air baffle (at left in cooking chamber)

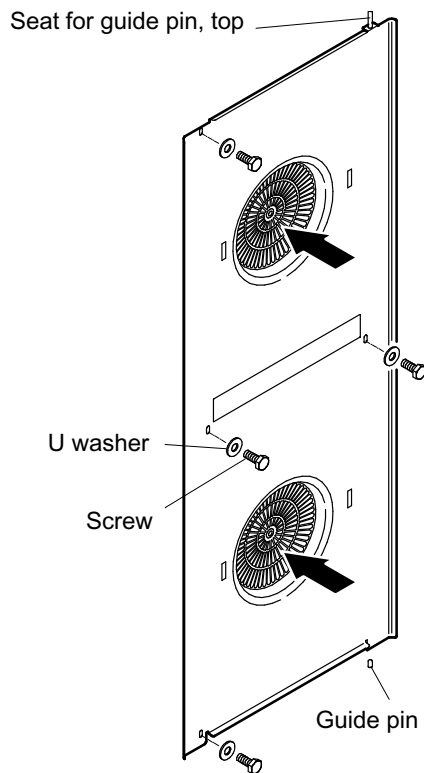

Inserting the air baffle, Type 2011, 2021QT

☞ Insert air baffle into the guide pins:

1. Insert at top
2. Lift air baffle
3. Insert at bottom
4. Secure with four screws and U washers.

5.1.4 Inserting the grease filter (optional)

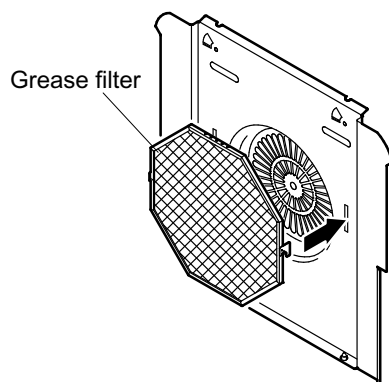

Attention! The grease filter can have an influence on the uniformity of baked products in particular.

- Use the grease filter preferentially with greasy foods

Information about "Preventing smoke development", refer to Page 18 Chapter 5.4

5.1.5 Inserting the removable racks

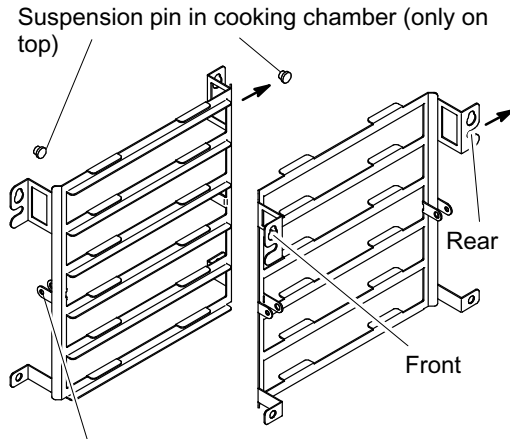

Core temperature sensor holder

Inserting the air baffle type 623T, 611T, and 1011T

- ☞ Push removable racks into suspension pins
 - at the rear,
 - hook in place in the front.
- The removable racks are identical at the left and right.

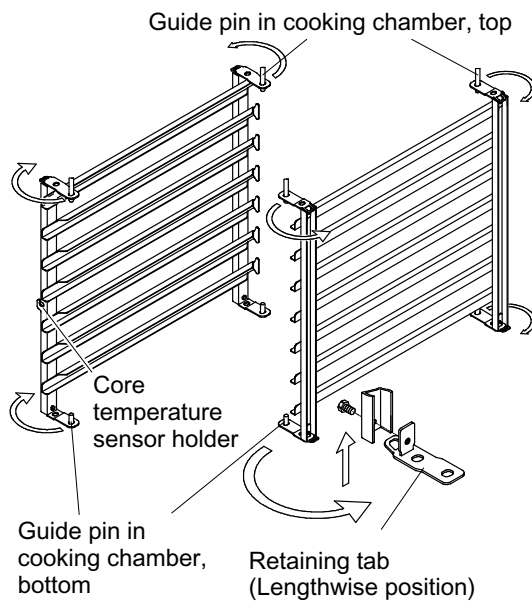

Insert the removable racks type 611, 621QT and 1011, 1021QT

- By converting the retaining tab, the removable racks can be used for lengthwise or crosswise positioning or for bakery standard.
- Do not mix up the left and right removable racks.
- Careful, do not bend the upper guide pins! Do not tilt the removable racks whilst inserting them!
- ☞ Hook the removable rack
 - on the upper guide pins,
 - push upward,
 - insert into the lower guide pins and
 - lower it.

5.2 Inserting/removing removable racks/rack trolleys (option)

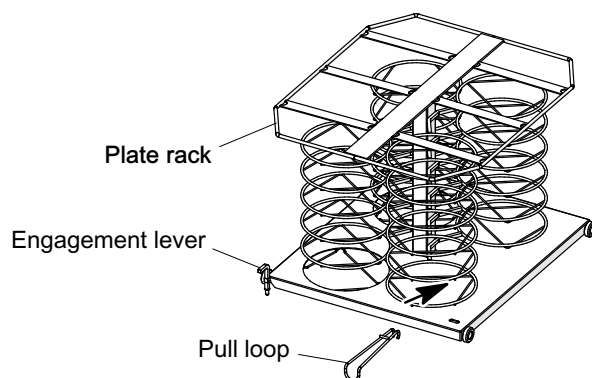
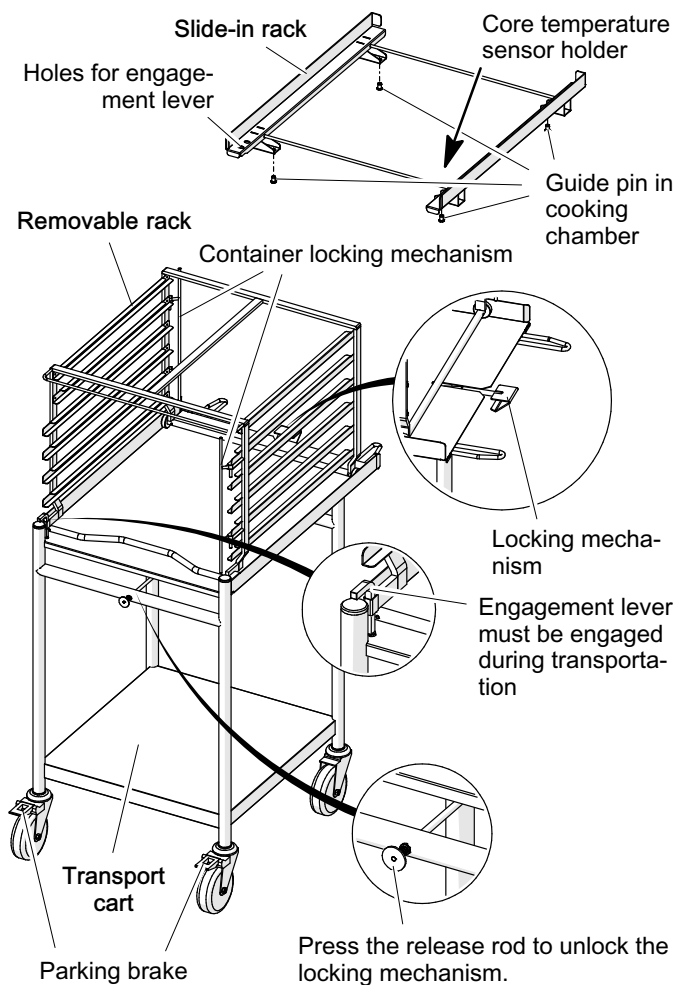

Rack trolley, e.g. for type 2011, 2021

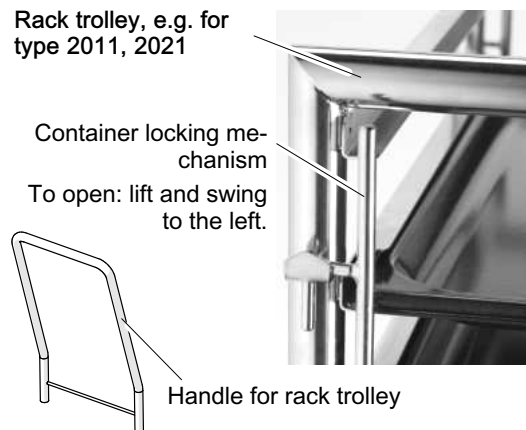

WARNING! Risk of injury! Rack trolleys/ transport carts as well as appliances on wheels may tip over when transported across slanted surfaces or thresholds!

Caution hot! Wear protective gloves to move removable racks/rack trolleys!

- ☞ Close Gastronorm containers with their lids before transportation, to prevent hot liquids from spilling over.
- ☞ Close the locking mechanism after inserting the containers into the rack trolley or removable rack.
- ☞ Do not bang against the appliance or door seal when inserting a rack trolley or removable rack into the cooking chamber.
- ☞ Activate the parking brake while the transport cart/rack trolley is not being moved to prevent it from inadvertently rolling away.

Using a removable rack

- ☞ Remove racks from cooking chamber.
- ☞ Place the slide-in frame in the cooking chamber. Ensure exact fixing with the guide pin!
- ☞ Secure the removable rack on the transport cart against movement by using the engagement lever.
- ☞ Adjust the appliance with the screw-in feet if the height of the transport cart and slide-in frame are not aligned.
- ☞ Move the transport cart up to the appliance until the locking mechanism on the cooking chamber engages and the transport cart is thus secured against rolling away.
- ☞ Lift the engagement lever and slide the removable rack into the cooking chamber.
- ☞ Secure the removable rack to the slide-in frame with the engagement lever.
- ☞ Use the pull loop to remove the plate rack.



Using a rack trolley

- ☞ Immediately detach the handle after inserting the rack trolley (risk of glass breakage or damage to the cooking chamber door)!
- ☞ Actuate the parking brakes on the rack trolley after sliding it into the cooking chamber and closing the cooking chamber door to prevent it from moving unchecked after opening the cooking chamber door.
- ☞ Always use the detachable handle to pull the rack trolley out (risk of burns from hot surfaces)!

5.3 Switching on the device

- ☞ Open the water tap.
- ☞ Switch on the mains switch for the appliance.

The appliance is equipped with different main switches, depending on the type of appliance and year of manufacture:

 Touch-key with LED indicator light	 Switch with LED ring indicator light
<ul style="list-style-type: none"> ● The red LED in the ON/OFF button lights up. ☞ Switch the appliance on - tap the "on/off" key. ● The red LED in the ON/OFF button switches off. 	<ul style="list-style-type: none"> ☞ Switch the appliance on - press the "on/off" key. ● The ring indicator light illuminates.

- The cooking chamber lighting illuminates after approx. 3 seconds.
- An appliance logo will be displayed on the touch-screen for approx. 1 minute.



Please note! The appliance is computer-controlled!

Therefore do not turn the device on and off in quick succession, as this could result in errors. The computer controller needs a bit of time to load all data or to shut the system down properly. Therefore wait about 30 seconds after turning the device off before turning it back on again.

Select products / make settings, see from Page 24 Chapter 6.

5.4 Prevent smoke development with greasy foods

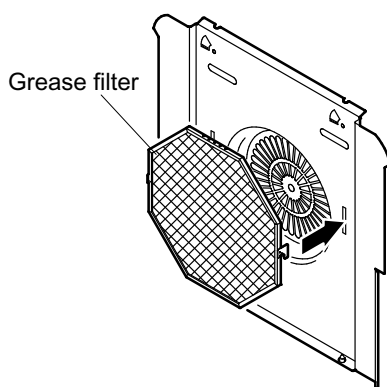

Attention! Incorrect settings can result in heavy smoke development, so that smoke detectors could be triggered!

How to reduce or prevent heavy smoke development:

- ☞ Use a grease filter, see page 15 chapter 5.1.4
- ☞ Reduce air speeds.
- ☞ Reduce cooking temperature.
- ☞ After cooking with greasy foods, clean the cooking chamber (*from Page 75 Chapter 13.*)

5.5 Loading

- Use only heat-resistant containers and GastroNorm containers (EN631).
- Grease dripping down during the cooking process must not enter the cooking chamber drain; a GN container must therefore be inserted in the lowest shelf for these types of food. Otherwise there will be a risk of clogging the water drainage system.



- Note the shelf heights for liquid foods and foods becoming liquid.
- For liquid or liquefying foods,
 - only fill the GN container to a maximum of 2/3,
 - only slide in the GN container at the level that can be easily viewed by the operating persons.

5.5.1 Maximum permissible loading weight



Exceeding the maximum loading weight may damage the appliance, the removable rack or the rack trolley. The appliance / removable rack / rack trolley must not be used if damage has occurred.

Size	623	611	621	1011	1021	2011	2021
Appliance model	T	T / QT	QT	T / QT	QT	QT	QT
Per appliance / removable rack / rack trolley	60 kg	60 kg	60 kg	100 kg	100 kg	150 kg	150 kg
Per insert	15 kg	15 kg	15 kg	15 kg	15 kg	20 kg	20 kg

5.5.2 Using the core temperature sensor



- **CAUTION! Risk of burning!** The core temperature sensor and the handle may be very hot! Use protective gloves!

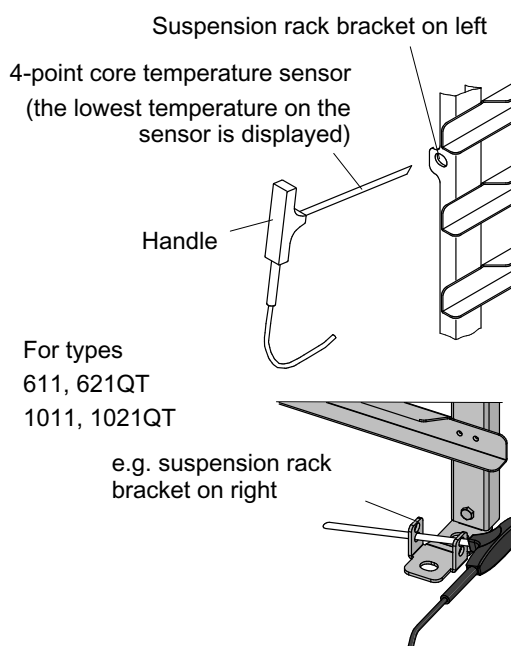

- The core temperature sensor must not protrude beyond the cooking chamber (damage to the glazing or core temperature sensor when closing the cooking chamber door).
- ☞ Poke the core temperature sensor in the centre at the thickest point into the food to be cooked.
- If the food to be cooked is frozen, push the core temperature sensor only into prepared holes. Do not force into the frozen food to be cooked.
- Insert the core temperature sensor into the holder when not used.
- Before removing the food from the cooking chamber pull the core temperature sensor first from the cooked food and insert it in the holder (risk of damage)!

Core temperature sensor - from 2022, Type 2011/2021

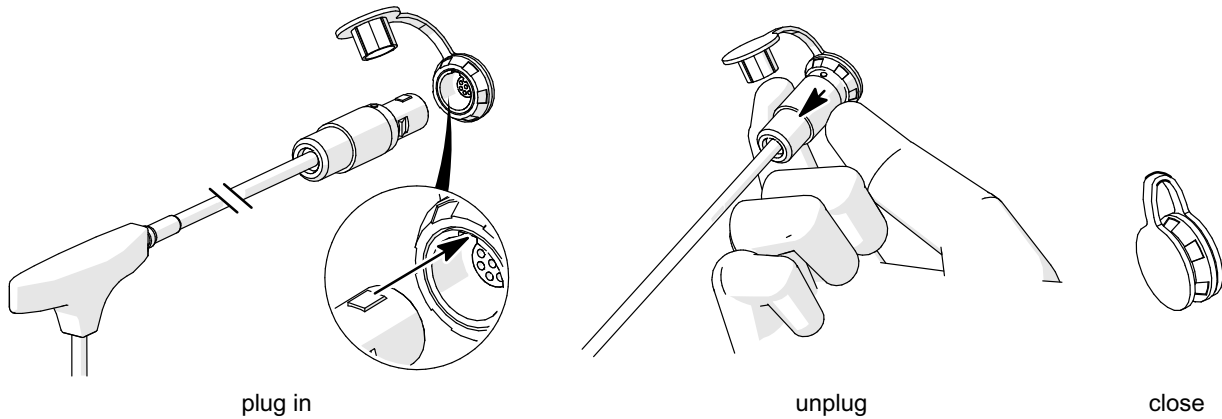

5.5.3 Using the Sous-Vide sensor (option)



- **CAUTION! Risk of burning, risk of injury!** The Sous-Vide sensor and the handle can become hot! The Sous-Vide sensor has a sharp point! Use protective gloves!
- The Sous-Vide sensor must not protrude beyond the cooking chamber (damage to the glazing when closing the cooking chamber door).

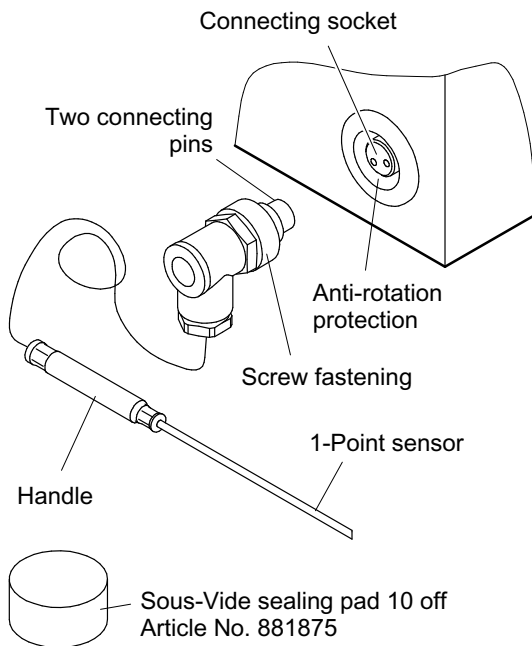

Connecting to the appliance

- ☞ Remove the cover from the connecting socket.
- **Caution! Do not bend the connecting pins!**
- **Observe the anti-rotation protection of the angle plug and socket!**
- ☞ Insert the angle plug.
- ☞ Connect the angle plug to the screw fastening.

Insert into the food to be cooked

- **Caution! Do not bend the Sous-Vide sensor!**
- ☞ Bond a Sous-Vide sealing pad at the thickest position in the food to be cooked.
- ☞ Insert the Sous-Vide sensor into the food to be cooked, through the sealing pad. Position the point of the Sous-Vide sensor in the centre of the food to be cooked.
- ☞ After using the Sous-Vide sensor on the appliance, remove and safely store.
- ☞ Remove the cover from the connecting socket.

Using special programs, refer to Page 33 Chapter 6.5

5.6 Starting / ending the cooking process

5.6.1 Starting the cooking process

Select products / make settings, see from Page 24 Chapter 6.

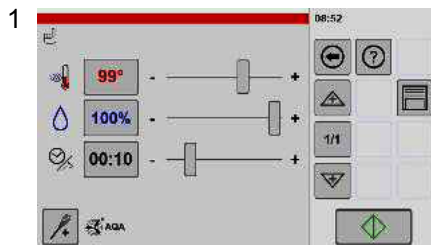

Start cooking process



- The symbol in the key glows green.

Tap the key "Start/Stop".



- The symbol in the "Start/Stop" key changes from green to red.
- The cooking process is running.
- The time runs down. The remaining time is displayed.
- The progress bar indicates the time progression graphically.
- You can make changes during the cooking process.
- Steaming operating mode: If the temperature in the cooking chamber is too high, the cooking chamber is cooled down. The temperature on the display flashes during the cooling down process.
- Core temperature function: The cooking process does not start if the core temperature sensor is not inserted into the food to be cooked or the target temperature is not set. A prompt is shown on the display panel.

Gas appliances only: Flame symbol gas burner heating

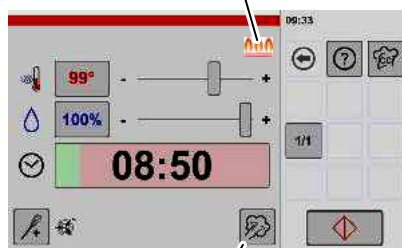

"Manual steam injection" button

Displaying the actual temperature in the cooking chamber.



Tap the "Temperature" key.

- The actual temperature is shown for approx. 5 seconds.

"Start/Stop" key info presentation



Green: The cooking process can be started.



Red: The cooking process is running. The cooking process can be interrupted by tapping the "Start/Stop" key.



Blue: Shows the completion of a heating or cooling process. The controller waits for a confirmation to start the cooking time countdown.

The cooking time countdown starts only after

- loading the cooking compartment, by opening and closing the door of the cooking compartment

or

- after tapping the key "Start/Stop".

5.6.2 End of the cooking process



WARNING! Scalding hazard! Carefully open the cooking chamber door! Allow steam and hot air to escape to prevent a hazard to any person!

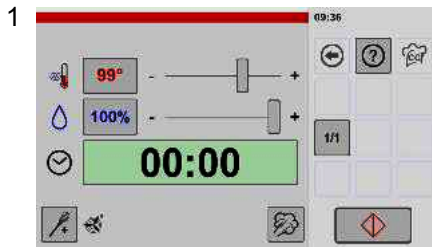

End of cooking process

- After expiry of the cooking process, an acoustic signal sounds.

Setting the sound and light signal, see from Page 58 Chapter 10. (Figure 6)

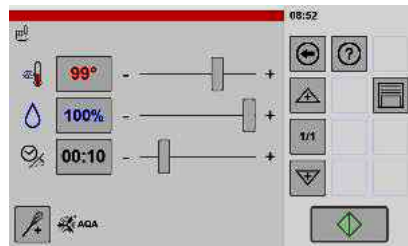

After opening the cooking chamber door, or tapping the key "Start/Stop":

- The symbol in the "Start/Stop" key changes from red to green.
- The cooking parameters previously set are displayed again.

5.6.3 Removing the containers



- **CAUTION** During operation there is a risk of burns from
 - hot surfaces,
 - hot cooked products,
 - hot removable racks,
 - hot rack trolleys and
 - hot escaping steam when opening the cooking chamber door.



- **WARNING! Scalding hazard! Caution! Hot surfaces and containers! Caution! Hot liquids slopping over.** Wear suitable protective clothing, protective gloves!
- ☞ Cover containers with liquid foods before removing them to prevent any risk of scalding from liquids slopping over.
- ☞ The cooking chamber must be cleaned if no other cooking process follows the removal of the food items. Otherwise risk of clogging in the drain from solidifying grease (*Cleaning see page 75 Chapter 13.*)

5.7 Cooling of the cooking chamber with cooking chamber door open

This function allows opening and closing the cooking chamber door during the cooling process.



WARNING! Scalding hazard! Carefully open the cooking chamber door! Allow steam and hot air to escape to prevent a hazard to any person!

WARNING! Risk of injury! The device may not be operated without air baffle!

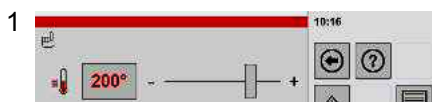

Example

The cooking chamber temperature is 200 °C and shall be cooled to 80 °C.

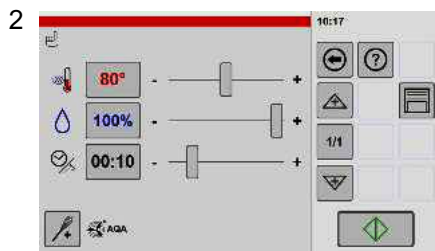

Selecting auxiliary functions

Example: "Steaming" window is selected.



- ☞ Tap the "Auxiliary functions" key.
- The window "Auxiliary functions" is displayed.



Setting the auxiliary "Cooling" function (Temp-Active)



- ☞ Touch the "Temp-Active" key.
- The key is highlighted in colour.



- ☞ Confirm the set auxiliary function with "Enter".
- The "Settings" window will be displayed.

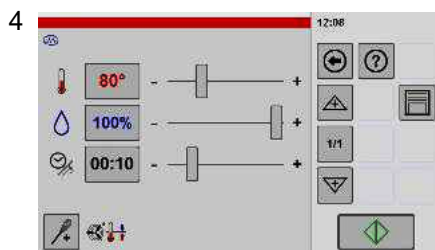

Start "Cooling"



- ☞ Tap the key "Start/Stop".
- The "Note" window is displayed.

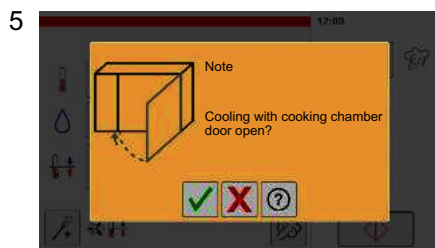

Confirm "Cooling" / Open cooking chamber door



- ☞ Touch the "Confirm" key within 5 seconds or open the cooking chamber door.
- The function "Cooling with cooking chamber door open" is now active.
- The "Cooling" window is displayed.
- The "Cooling with cooking chamber door open" function is not activated if the note was not touched within 5 seconds. To cancel/repeat the process: Tap the key "Start/Stop".

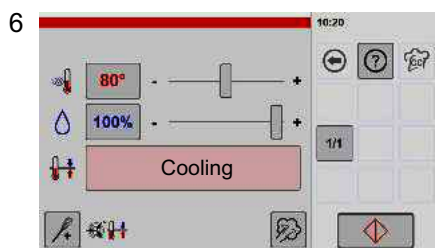

Cooling process

- The temperature on the display flashes during the cooling process.
- The fan wheel runs during the cooling process, steam generation is disabled.
- The temperature can be changed during the cooling process.

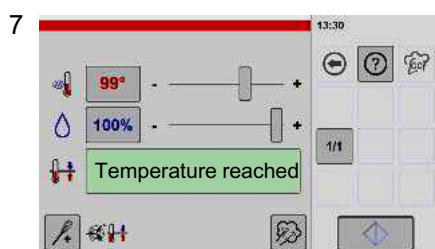

Cooling process completed

- After the temperature has been reached, the message "Temperature reached" is displayed and the "Start/Stop" key lights up blue.



- ☞ The cooking time countdown starts only after
 - loading the cooking compartment, by opening and closing the door of the cooking compartment
 - or
 - after tapping the key "Start/Stop".

6. Using operating modes, cooking programs

All options are described in this Chapter 6.. The figures and functions can deviate from the figures presented here, depending on the equipment of the appliance.

6.1 Setting the cooking process - manual settings



With this function you work with the four operating modes steaming, hot air, combi-steaming and vitalisation.

This chapter (6.1) provides you also with information on basic functions and their setting options.



Start manual settings



- ☞ Tap the "Hand" key.
- The "Operating Modes" window will be displayed. (Exemplary figure: Equipment Pro with option for baking).



Selecting the operating mode



- ☞ For example, tap the "Steaming" key.
- The "Settings" window is displayed.

Operating mode info:



Steaming



Hot air



Combi-steaming



Vitalising



Special programs

For applications, refer to Page 33, Chapter 6.5

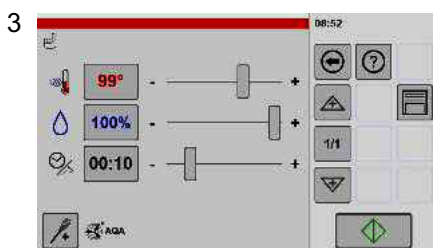

Making the settings / starting the cooking process



- ☞ Tap the key "Start/Stop".
- The symbol in the "Start/Stop" key changes from green to red.

For the cooking process window, refer to Page 21 Chapter 5.6.1

or change the values with the slider control or the numeric keypad:



- ☞ Using the slider control: Tap the slider control and move to the left or right.
- The value to the left of the slider control changes.



- ☞ With numeric keypad: Tap the number to be changed.
- The numeric keypad is displayed (see figure 4).

Set the auxiliary functions, if needed:



- ☞ Tap the Auxiliary functions key.
- The "Auxiliary Functions" window is displayed (see figure 7).

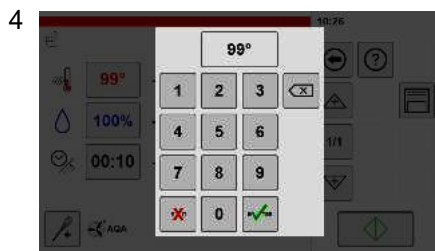

Changing values with the numeric keypad

☞ Enter the required value.



☞ Confirm the value entered with "Enter".

- The numeric keypad is closed. The value has been saved.

Key functions info:



Delete from right to left



Close numeric keypad without saving



Confirm entry and close numeric keypad.

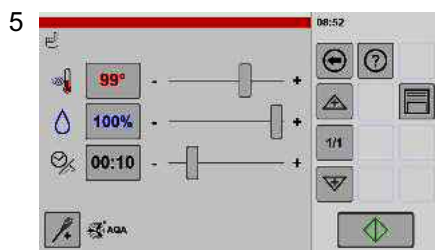

Switching the time according to core temperature

Using the core temperature sensor, refer to Page 19 Chapter 5.5.2

There are two options of selecting the core temperature function.

1. Option - Change over with the key "Core temperature" adjacent to the temperature display:



☞ Tap the key "Time/Core temperature".

- The symbol switches to "Core temperature".
- The display switches from time to temperature.

2. Option - Change over with numeric keypad:



☞ Tap the "Core temperature" key.

- The key is shaded dark grey and framed.
- The display switches from time to temperature.

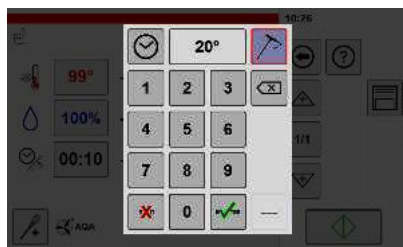

Key functions info:



Symbol next to display: Time is activated.



Symbol next to display: Core temperature is activated.



In the numeric keypad: Core temperature (activated = shaded dark grey and framed)



In the numeric keypad: Time

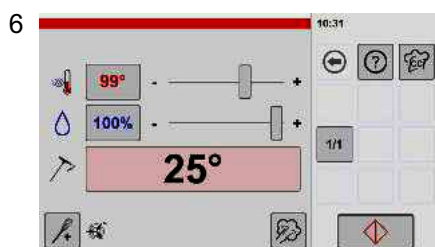

Displaying/changing setpoint core temperature during cooking process

- During the cooking process, the current temperature of the core temperature sensor is displayed.



☞ To display or change the setpoint core temperature, touch "Time/Core Temperature".

- The numeric keypad with setpoint core temperature is displayed.

7

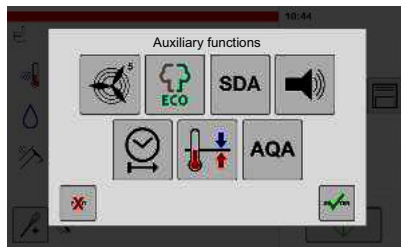

Selecting auxiliary functions

- ☞ Tap the required "Auxiliary Functions".
 - The key is shaded dark grey and framed.
- ☞ Confirm the set auxiliary function with "Enter".
 - The "Settings" window will be displayed again.
 - The auxiliary functions set are displayed again in the window.



Auxiliary functions window:

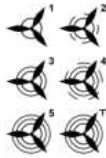

Ventilator speeds in five stages and cycled (T).

Select the desired ventilator speed by tapping the key several times until the desired ventilator speed is displayed.



Eco Mode: Reduced heat output.

SDA

Safety steam extraction at the end of the cooking process. (this function is not available if the core temperature is used).



Signal and message window, output after expiry of the cooking step, e.g. for basting, seasoning or turning the food to be cooked. Has an effect on the signal, activated light signal and external signals.



Start time/end of cooking preselection: Pre-select start or end of the cooking process. Refer to the following figure regarding making the settings 8

Temp-Active: Preheating / Cooling before the cooking process



- After a heating or cooling process the controller waits for an entry confirmation. Displayed by blue symbol in the key "Start/Stop".

Application "Cooling of the cooking chamber with cooking chamber door open" refer to page 22 chapter 5.7!



The cooking time countdown starts only after

- loading the cooking compartment, by opening and closing the door of the cooking compartment
- or
- after tapping the key "Start/Stop".

AQA

Automatic Quantity Adaptation (quantity recognition and cooking time adaptation).



Closing the auxiliary functions window without confirming the change (Cancel).



Confirm settings and close window.

8

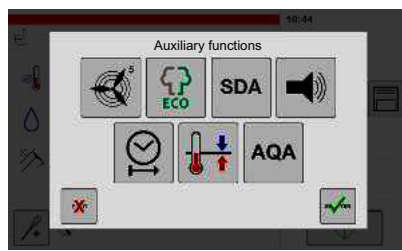

Selecting the "Start time/end of cooking" auxiliary function

The start time or the end of cooking can be preset. When using the core temperature, the end of cooking setting is not available.

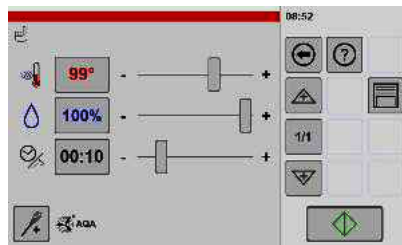

- ☞ Tap the "Start time/end of cooking" key.
- The key is shaded dark grey and framed.



- ☞ Confirm the set auxiliary function with "Enter".
- The "Settings" window will be displayed again.
- The symbol for the start time/end of cooking is displayed in the window.



- ☞ Tap the key "Start/Stop".
- The start time/end of cooking window will be displayed.



- ☞ Set the start time or end of cooking with the slider control or the numeric keypad.
- Depending on the cooking time set, the start time or the end of cooking is automatically converted and displayed (except when AQA is activated).



- ☞ Tap the key "Start/Stop".
- The set time runs down.
- The time remaining until the start of the cooking process is displayed.

9



Reset to factory start screen.



- ☞ Tap the "Back" key for approx. 2 seconds.



- The symbol in the key changes.
- The start screen appears again after releasing the key.
- All manual settings previously made are reset to the default values.
- Manually set cooking steps are deleted.

6.2 Cooking steps to add / combinations

Up to 20 cooking steps can be combined. Option cookbook: The cooking steps can be stored in the cook-book (refer to Page 44 Chapter 7.1).

1 Selecting the operating mode (1. cooking step)



- ☞ For example, tap the "Steaming" key.
 - The "Settings" window is displayed.

Operating mode info:

- Steaming
- Hot air
- Combi-steaming
- Vitalising
- Special programs
For applications, refer to Page 33, Chapter 6.5

2 Make the settings and add the 2nd cooking step

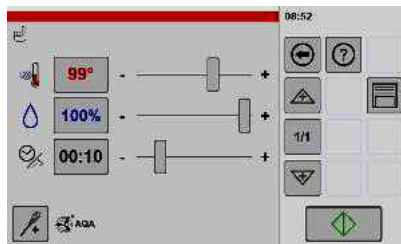

- ☞ Make the settings, e.g. temperature, humidity, time, core temperature, auxiliary functions.

- ☞ Tap the key "New cooking step".
 - A new window for "Settings" is displayed.
 - The "1/1" display switches to "2/2".
 - If you require additional cooking steps, repeat this step until all desired cooking steps are created.

Key functions info:

- Switching up or down in the cooking steps (only if several cooking steps are stored).

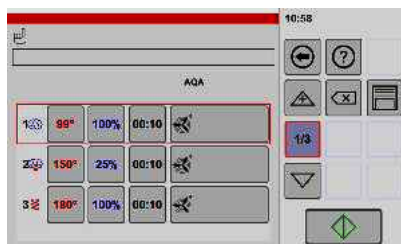

- ☞ Tap and momentarily press the key "Arrow".
 - The symbol changes to the symbol "New cooking step".
 - After releasing, the window Operating modes is displayed.

- ☞ Tap and momentarily press the key "Arrow".
 - The symbol changes to the symbol "New cooking step".
 - After releasing, the window Operating modes is displayed.

- ☞ Tap and momentarily press the key "Arrow".
 - The symbol changes to the symbol "New cooking step".
 - After releasing, the window Operating modes is displayed.

- Add a new cooking step before or after the cooking step marked.

- Switching to the cooking steps overview.
Refer to next figure for description 3

3 Touch the value

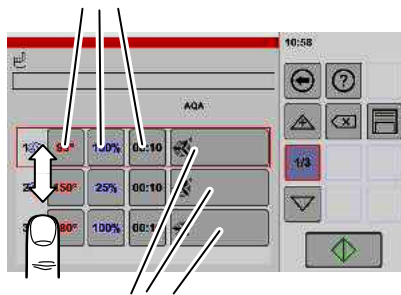

Auxiliary functions:

Fan speeds, Eco-Mode, Safety steam extraction, Preselection of start time-end of cooling, Temp-Active, Automatic quantity adjustment

Display/change of cooking steps in overview window



- Tap the "Cooking steps overview" key.
- The "Cooking steps overview" window will be displayed.



If more cooking steps are created than can be shown on the display screen:

- Tap the screen with finger and move the cooking steps displayed up or down.



- Each value displayed can be changed by tapping it.



- After the change has been made, the settings for the current cooking process can be started.



- Cooking steps can be deleted individually (refer to next Figure5).
- All cooking steps are deleted by switching back to the start screen.

Appliance type Easy without option cookbook:

- The settings of the cooking steps are stored only for the current cooking process. The settings are no longer preserved after switching the appliance off and on again.

Option cookbook:

- If the settings are not stored in the cookbook, they are no longer available after switching the appliance off and on (Saving in cookbook, refer to Page 44 Chapter 7.1).

4

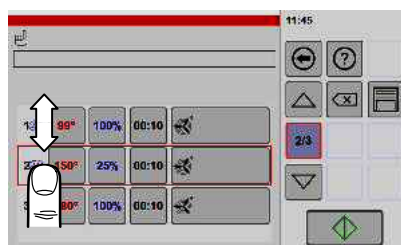

Start cooking steps - Start any cooking step

By default, cooking steps are processed in sequence. However, cooking can also be started with any step.



- Tap the "Cooking steps overview" key.
- The "Cooking steps overview" window will be displayed.



If more cooking steps are created than can be shown on the display screen:

- Tap the screen with finger and move the cooking steps displayed up or down.



- Touch the cooking step to be deleted on the cooking step number.
- The cooking step is framed.

Tap the key "Start/Stop".

- The symbol in the key "Start/Stop" changes from green to red.
- The cooking process starts with the selected cooking step.

5

Deleting individual cooking steps in the overview window

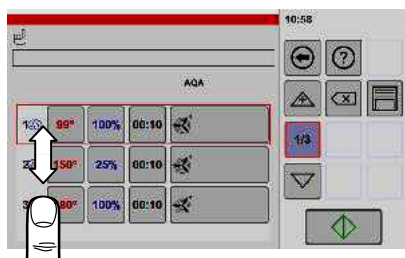

1/3

- Tap the "Cooking steps overview" key.
- The "Cooking steps overview" window is displayed.



If more cooking steps are created than can be shown on the display screen:

- Tap the screen with finger and move the cooking steps displayed up or down.



- Tap the cooking step to be deleted on the cooking step number.

- The cooking step is framed.



- Tap the "Delete" key.

- The cooking step is deleted.

6

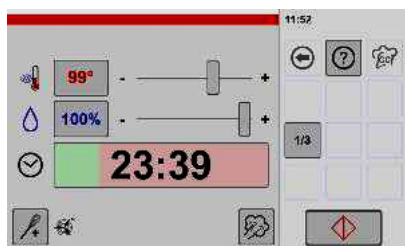

Display of started cooking steps

- After starting the cooking process, the sum of the cooking times of all cooking steps set is displayed.
- The remaining time is displayed.
- The progress bar indicates the elapsed time graphically.
- Settings can be made during the cooking process (see figure 3 in this Chapter).
- This cooking step combination can be started again after the cooking process has run down.

Notes on auxiliary functions after starting the cooking process

- If the auxiliary function preheating is enabled, a preheating process starts. After the preheating process has expired, the cooking process must be started by pressing the key "Start/Stop" or by opening and closing the door of the cooking chamber (loading process).
- AQA: If the auxiliary AQA function is enabled, the quantity/cooking time is adjusted depending on the quantity of the cooking product. After the quantity/cooking time has successfully been adjusted, the specified cooking time starts.

6.3 Using vitalising



If this function is enabled, the key "Vitalising" is displayed.

Add the key "Vitalising" in the home screen, see from Page 58 Chapter 10. (Figure 13).

With these functions you can prepare the foods ready-to-serve specifically for the à la carte or banquet business



Start Vitalising



- ☞ Tap the "Vitalising" key.
- The "Vitalising" window will be displayed.

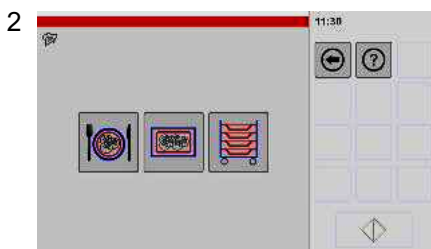

Select



- ☞ For example, tap the "Vitalising plate" key.
- The "Settings" window is displayed.

Key functions info:



Vitalising plates



Vitalising foods in containers, e.g. GN container



Vitalising banquet system

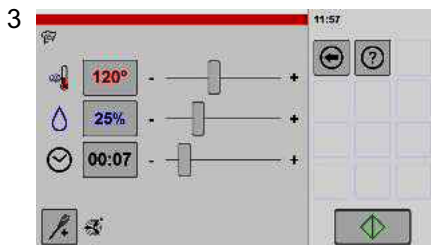

Starting the cooking process



- ☞ Make adjustments if necessary
- ☞ Tap the "Start/Stop" key.

6.4 Cooking process application



If this function is enabled, the key "Cooking process" is displayed.

Add the key "Cooking process" in the home screen, see from Page 58 Chapter 10. (Figure 13).

Nine preset cooking processes are set in the cooking process feature.



Start cooking process



- Tap the "Cooking process" key.
- The "Cooking process" window will be displayed.



Cooking process selection

- Tap the required cooking process.
- The cooking process window with the preset values is displayed.

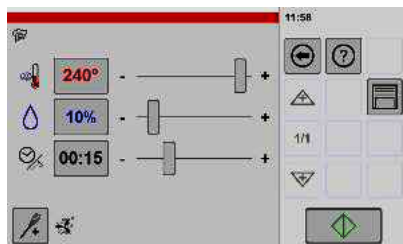

- Change the values with the slider control or the numeric keypad.











Refer to page 25 figure 4 for the use of the numeric keypad.



Starting the cooking process, see page 21 Figure 1.

Cooking process info (approximate values)







Description	Temperature	Time / Core temperature	Humidity
 "Au gratin" cooking	250 °C	00:15	0 %
 Broiling	230 °C	00:20	0 %
 Braising	140 °C	Core temperature 75 °C	80 %
 Frying	200 °C	00:30	20 %
 Vitalising plates	120 °C	00:10	30 %
 Defrosting	30 °C	00:20	60 %
 Steaming 99°C	99 °C	00:15	100 %
 Stewing 95°C	90 °C	00:15	100 %
 Poaching 85°C	80 °C	00:10	100 %

6.5 Special programs application

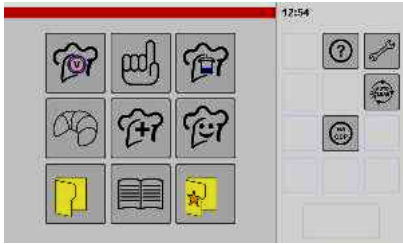

The "Special programs" key is displayed and enabled if the appliance is equipped with this option.

Add the key "Special programs" in the home screen, see from Page 58 Chapter 10. (Figure 13).

- 1  **Start manual settings**
 -  Tap the Hand key.
 - The "Operating Modes" window will be displayed.
- 2  **Selecting special programs**
 -  Tap the key "Special programs".
 - The "Special programs" window will be displayed.
 - Special programs and cooking processes can also be combined, e. g. Cook and Hold, NT cooking and steaming.
- 3  **Selecting the program**
 -  For example, tap the "Delta T cooking" key.
 - The "Settings" window is displayed.

Special programs info



Delta T Cooking

- Suitable for all larger meat joints or roasts.
- Uniform temperature differential between the cooking chamber and core temperature during the cooking process.



Cook and Hold

- Two-stage program with a cooking and temperature maintenance phase.



NT - Cooking over night

- Tap the "NT Overnight cooking" key. Default setting with several cooking steps is displayed. The help function contains suggestions for products with settings.
- High requirement on hygiene required! If uncooled or unheated food is in the cooking chamber, e.g. bacteria can very quickly multiply!



Slide-in time

(refer to Page 34 Chapter 6.6)!



Soft Cooking

- Program with a maturity phase of less than 100°C.



Sous Vide

- Gentle cooking in a vacuum bag.
- High requirement on hygiene required!

Using the Sous-Vide sensor, refer to Page 20 Chapter 5.5.3

6.6 Working using slide-in times



This function is included in the special programs.

A cooking time can be allocated to each slide-in level for the operating mode used.

Add the key "Special programs" in the home screen, see from Page 58 Chapter 10. (Figure 13).



Start manual settings



- ☞ Tap the key "Hand".
- The "Operating Modes" window is displayed.



Start special programs



- ☞ Tap the key "Special programs".
- The "Special programs" window will be displayed.



Start slide-in times



- ☞ Tap the key "Slide-in times".
- The "Settings" window is displayed.

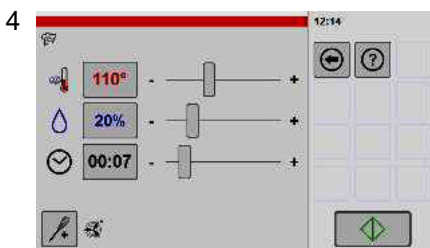

Making the settings for the cooking process



- ☞ Making the settings.
- The slide-in time/cooking time set is automatically used as the presetting for all slide-in levels.
- After selecting a slide-in level, this slide-in time can again be changed and, thus, be adapted.



- ☞ Tap the key "Start/Stop".
- The "Slide-in levels" window is displayed.

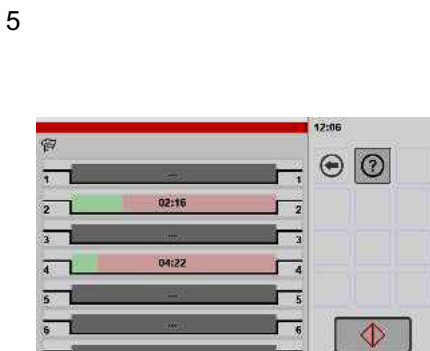

Loading the cooking chamber and starting the cooking process

- ☞ Put the food in the cooking chamber.
- ☞ Close the cooking chamber door.
- ☞ Tap the icon "Slide-in level".
- The previously set cooking temperature is displayed.
- The progress bar indicates the time progression graphically.
- The time runs down. The remaining time is displayed.

Changing the slide-in time, refer to the following Figure 7!

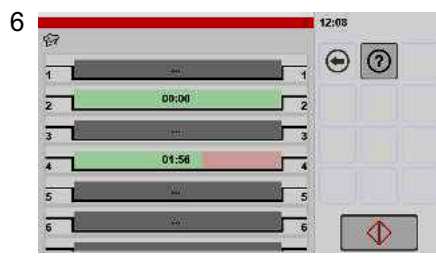

6 End of cooking process

- After expiry of a slide-in time, an acoustic signal sounds.
 - The corresponding symbol for "Slide-in level" flashes.
- ☞ Open the cooking chamber door.
- The expired slide-in time/cooking time goes out.
 - Whilst the cooking chamber door is open, the slide-in times do not run.
- ☞ Remove the food from the corresponding slide-in level.
- ☞ Close the cooking chamber door.
- Remaining slide-in times continue.



7 Changing slide-in times, interrupting slide-in level

The slide-in times can be changed at any time.



- ☞ Tap the enabled symbol "Slide-in level".
- The numeric keypad is displayed.
- ☞ Enter the required value.
- ☞ Confirm the value entered with "Enter".
- The numeric keypad is closed.
- ☞ To interrupt the slide-in time, set 00:00.
- ☞ Tap the "Delete" key.
- The slide-in level is deleted.



8 Cancelling/deleting all slide-in levels/times



- ☞ Touch "Start/Stop".
- The Warning window is displayed.



- ☞ Touch "Confirm".
- All slide-in levels/times are deleted.
 - The "Settings" window is displayed.

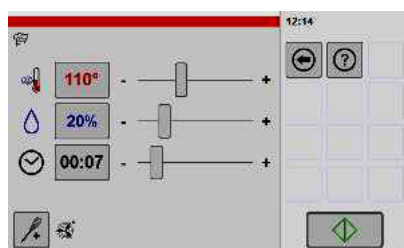

6.7 Using combi-cooking



This function is a part of the cookbook.

It permits the simultaneous cooking of different products at different times.

Programs in the cookbook are available for combi-cooking, according to the cooking chamber climate selected.



1 Display cookbook

- Combi-cooking is possible in manual mode and cookbook.
- ☞ For example, tap the key "Cookbook".
- The "Cookbook" window is displayed.



2 Select product

- ☞ Tap the desired product.
- The product is framed.
- ☞ Put the food in the cooking chamber - e.g. use slide-in level "1".
- ☞ Tap the key "Start/Stop".
- The cooking process is started.
- The "Cooking process" window will be displayed.

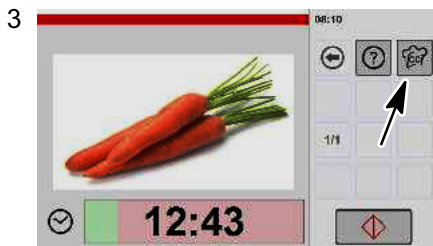

3 Cooking process window



- ☞ Tap the key "Combi-cooking".
- The "Combi-cooking" window is displayed.



4 Making the settings for the cooking process

- If no input is made within approx. 5 seconds,
 - the slide-in level function switches off,
 - the cooking process window is again displayed.
- ☞ Tap the icon "Slide-in level 1".
- The previously selected product is allocated to the slide-in level "1".
- ☞ Put the food in the cooking chamber - e.g. use slide-in level "2".
- ☞ Tap the icon "Slide-in level 2".
- Products from the cookbook that correspond to the cooking chamber climate are displayed.



5 Select the next product



- ☞ Select a second product for slide-in level "2".
- The product is framed.
- ☞ Tap the key "Enter".
- All slide-in levels set are displayed.



Slide-in levels window

- The time runs down. The remaining time is displayed.
 - The progress bar indicates the time progression graphically.
- Changing the slide-in times, refer to the following Figure 8!*
- After expiry of a slide-in time, an acoustic signal sounds.
 - The corresponding symbol for "Slide-in level" flashes.



End of cooking process

- After expiry of a slide-in time, an acoustic signal sounds.
 - The corresponding symbol for "Slide-in level" flashes.
- ☞ Open the cooking chamber door.
- The expired slide-in time/cooking time goes out.
 - Whilst the cooking chamber door is open, the slide-in times do not run.
- ☞ Remove the food from the corresponding slide-in level.
- ☞ Close the cooking chamber door.
- Remaining slide-in times continue.



Changing slide-in time, interrupting slide-in level

The slide-in times can be changed at any time.

- ☞ Tap the enabled symbol "Slide-in level".
- The numeric keypad is displayed.
- ☞ Enter the required value.
- ☞ Confirm the value entered with "Enter".
- The numeric keypad is closed.
- ☞ To interrupt the slide-in time, set 00:00.
- ☞ Tap the "Delete" key.
- The slide-in level is deleted.

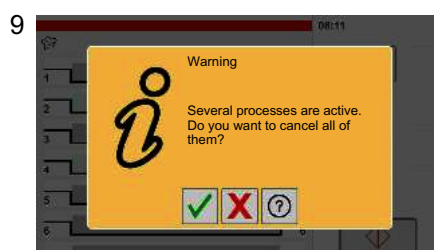

Cancelling/deleting all slide-in levels/times

- ☞ Touch "Start/Stop".
- The Warning window is displayed.
- ☞ Touch "Confirm".
- All slide-in levels/times are deleted.
 - The "Settings" window is displayed.

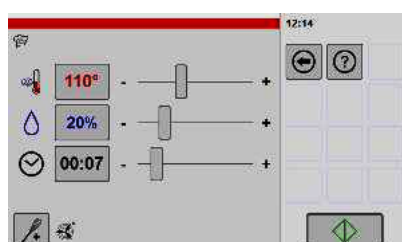

6.8 Applying the SmartCooking program



If the appliance is equipped with this option and it is enabled, the key "SmartCooking" is displayed.

Add the key "SmartCooking" in the home screen, see from Page 58 Chapter 10. (Figure 13).

SmartCooking offers a selection of automated cooking processes depending on product, product size, and cooking mode. Please note that various settings may be required depending on the product and other factors.



Start SmartCooking



- ☞ Tap the "SmartCooking" button.
- The "Settings" window appears.



Selecting the product



- ☞ For example, tap the "Meat" button.
- The "Product Size" window for the product category "Meat" appears.

Info on products:

Meat, Fish, Poultry, Vegetables, Side, Dessert

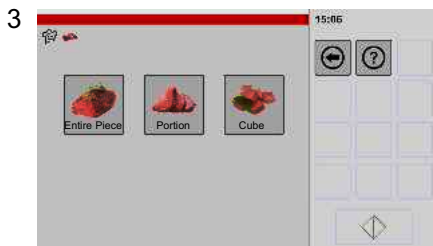

Product size selection



- ☞ For example, tap the "Entire Piece" button.
- The available "Cooking Processes" are displayed.

Info on product sizes:

The following product sizes can be selected depending on product.

- Meat (Entire Piece, Portion, Cube)
- Fish (Whole, Fillet, Piece)
- Poultry (Whole, Parts, Cube)
- Vegetable (Whole, Halved, Cut)
- Side (Potato Whole, Potato Cuts, Rice/Grain)
- Dessert (Portion, Medium, Large)



Cooking process selection



- ☞ Selecting the cooking process - e.g. tap the "Frying" button.
- The "Settings" window is displayed.

Cooking process info

The following cooking processes can be selected depending on the product.



Steaming



Braising



Frying

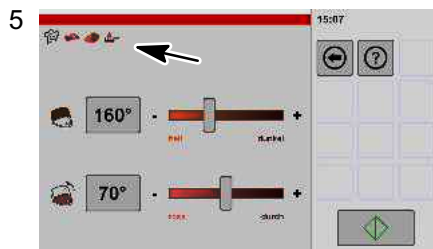

Starting the cooking process

- The selected functions are displayed in pictograms.

☞ Make adjustments if necessary.



☞ Tap the key "Start/Stop".

- The symbol in the key "Start/Stop" changes from green to red.

- A preheating process starts.

- After the preheating process has expired, an acoustic signal sounds and the key "Start/Stop" is highlighted in blue.

☞ Load the cooking chamber.

- Caution, the core temperature sensor is hot!

☞ Insert core temperature sensor into the food to be cooked.

☞ Close cooking chamber door.

- A reminder notice appears "Insert core temperature sensor". The notice automatically goes off after approx. 3 seconds.

- The colour in the key "Start/Stop" changes from blue to red.

- AQA: The quantity/cooking time is automatically adjusted. The process period depends on the quantity of food in the cooking chamber. After the quantity/cooking time has been adjusted, the specified cooking time automatically starts.

- The cooking process starts.

After the core temperature is attained

- A signal sounds.

- The colour in the key "Start/Stop" changes from red to green.

- The core temperature is displayed.

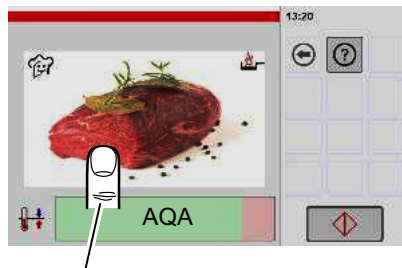
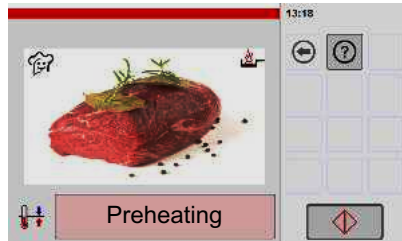

Changing settings during an active cooking process: tap on the screen to call up the "Settings" window for approx. 5 seconds.



6.9 Using cooking programs from the cookbook

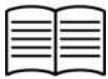

If the appliance is equipped with this option and it is enabled, the key "Cookbook" is displayed. Add the key "Cookbook" in the home screen, see from Page 58 Chapter 10. (Figure 13).

Products can be entered, changed and deleted in the cookbook (refer to Page 44 Chapter 7.). If the "Option "Baking" is included, baking programs are displayed in the cookbook.



1 Start Cookbook



- Tap the "Cookbook" key.
- The "Cookbook" window will be displayed.



2 Moving the display



- If more products are created than can be shown on the display screen:
- Tap the display screen with the finger and move the products displayed up or down.



3 Searching for product names



- The search function is possible in the pictogram or list display.
- Tap the "Search" key.
- Enter the search text, e.g. "sch".
- The search is not case-sensitive.
- Entry of a complete word is not required.
- The more precise the word to search for is entered, the shorter and clearer the results will be listed.
- Tap the key "Confirm".
- All products containing the characters "sch" entered in the word are displayed.



Key functions info:



Cancel



Confirm and start search



Switching the key assignment



Move the cursor to the left or right



Delete text from right to left



Switching the cookbook view



- Tap the "Change view" key.
- The display switches to pictogram view.



Key functions info:



Switching to pictogram view.



Switching to the list view.



Display/change of cooking steps in overview window

- Tap the desired product.
- The product is framed.
- Tap the key "Cooking steps overview".
- The "Cooking steps overview" window is displayed.



Key functions info:



Display of cooking steps overview.

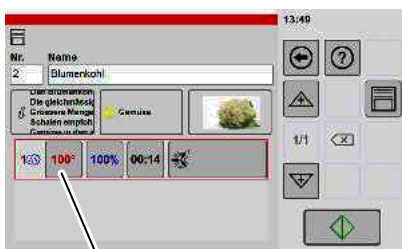

Tap the value



- Each value displayed can be changed by tapping it.



- After the change has been made, the settings for the current cooking process can be started.



- If the settings are not stored in the cookbook, they are no longer available after switching the appliance off and on (*Saving in cookbook, see page 44 Chapter 7.1*).



Changing settings during an active cooking process: tap on the screen to call up the "Settings" window for approx. 5 seconds.

Cooking process window - Cooking process started

- If preheating is enabled, after the preheating process has expired the cooking process must be started by loading or by pressing the key "Start/Stop".
- If AQA is enabled, the quantity/cooking time is automatically adjusted.
- The remaining time is displayed.
- The progress bar indicates the elapsed time graphically.
- The cooking process can be interrupted by tapping the "Start/Stop" key.

For the description of the "Finish cooking process", see from Page 22, from chapter 5.6.2

6.10 Working with categories (menu groups)



This function is a part of the cookbook.

Creating or deleting categories, refer to Page 50 Chapter 7.4!

1 **Start categories**

- Tap the "Category" key.
- The "Categories" (product groups) list is displayed.

2 **Moving the display**

- If more categories are created than can be shown on the display screen:
- Tap the display screen with the finger and move the products displayed up or down.

3 **Selecting the category**

- Tap the desired category.
- The selected category is framed.
- Tap the key "Enter".
- The content of the category is displayed.

Info key

- Confirm the selected category.

4 **Selecting the product**

- Move the display by tapping and moving up or down.
- Tap the desired product.
- The selected product is framed.
- Tap the "Start/Stop" key.
- The cooking process is started.
- The "Cooking process" window will be displayed.
- The symbol in the "Start/Stop" key changes from green to red.

5 **Cooking process window**

- If preheating is enabled, after the preheating process has expired the cooking process must be started by loading or by pressing the key "Start/Stop".
- If AQA is enabled, before the cooking process, the quantity/cooking time is automatically adjusted.
- The remaining time is displayed.
- The progress bar indicates the elapsed time graphically.
- The cooking process can be interrupted by tapping the "Start/Stop" key.

Changing settings during an active cooking process: tap on the screen to call up the "Settings" window for approx. 5 seconds.

6.11 Working with favourites (preferred products)



This function is a part of the cookbook.

In order to display favourites, these must be previously allocated.

Assigning products to favourites, see from page 44 Chapter 7.1 (Figure 7).



Starting favourites



- Tap the "Favourites" key.
- The "Favourites" window will be displayed.



Moving the display



- If more products are created than can be shown on the display screen:
- Tap the display screen with the finger and move the products displayed up or down.



Selecting the product



- Tap the desired product.
- The product is framed.
- Tap the "Start/Stop" key.
- The cooking process is started.
- The "Cooking process" window will be displayed.
- The symbol in the "Start/Stop" key changes from green to red.



Cooking process window

- If preheating is enabled, after the preheating process has expired the cooking process must be started by loading or by pressing the key "Start/Stop".
- If AQA is enabled, before the cooking process, the quantity/cooking time is automatically adjusted.
- The remaining time is displayed.
- The progress bar indicates the elapsed time graphically.
- The cooking process can be interrupted by tapping the "Start/Stop" key.

Changing settings during an active cooking process: tap on the screen to call up the "Settings" window for approx. 5 seconds.

7. Creating, changing, deleting products in the cookbook

This function is a part of the cookbook.

7.1 Creating, saving and assigning products



Up to 20 cooking steps can be combined.



1



Start manual settings



- ☞ Tap the "Hand" key.
- The "Operating Modes" window will be displayed.

2



Selecting the operating mode



- ☞ For example, tap the "Steaming" key.
- The "Steaming operating mode" window will be displayed.

Operating mode info:



Steaming



Hot air



Combi-steaming



Vitalising



Special programs

For description see page 33 chapter 6.5

3

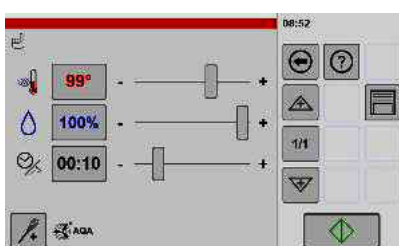

Making the settings

- ☞ Make the settings, e.g. temperature, humidity, time, core temperature, auxiliary functions.

If additional cooking steps shall be created, refer to the following figure 4.

If you want to save now, refer to the following figure 5.

4

Adding a cooking step

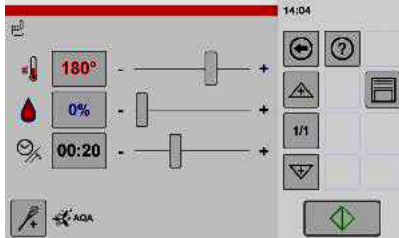

- ☞ Tap the "New cooking step" key.
 - The "Operating Modes" window will be displayed.

- ☞ Select the second mode of operation.
 - The "Settings" window is displayed.
 - The "1/1" display switches to "2/2".
 - If you require additional cooking steps, repeat this step until all desired cooking steps are created. Up to 20 cooking steps are possible.

Key functions info:



Switching up in the cooking steps (only if several cooking steps are stored).



Switching down in the cooking steps (only if several cooking steps are stored).



Add a new cooking step before the cooking step selected.

- ☞ Tap and momentarily press the key "Arrow".
 - The key symbol "New cooking step" is displayed.
 - The operating modes window is displayed.



Add a new cooking step after the cooking step selected.

- ☞ Tap and momentarily press the key "Arrow".
 - The key symbol "New cooking step" is displayed.
 - The operating modes window is displayed.



Add a new cooking step before or after the cooking step marked.



Switching to the cooking steps overview.

5

Opening the window for the save process



- ☞ Tap the key "Save".
 - The "Product entry" window will be displayed.
 - The next free number is suggested.

☞ Enter the desired number.

☞ Enter the desired name.

Key functions info:



Switching the key assignment.



Move the cursor to the left or right.



Delete text from right to left.

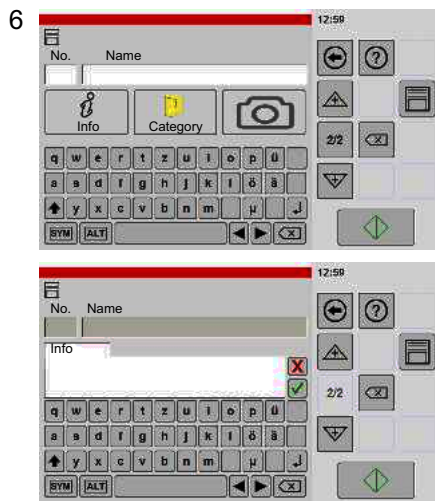

Adding an information item

Here you can enter your additional information.



- ☞ Tap the "Info" key.
 - A box for entering text is displayed.
- ☞ Enter the desired text.
- ☞ Tap the "Confirm" button.



Key functions info:



Confirm



Cancel

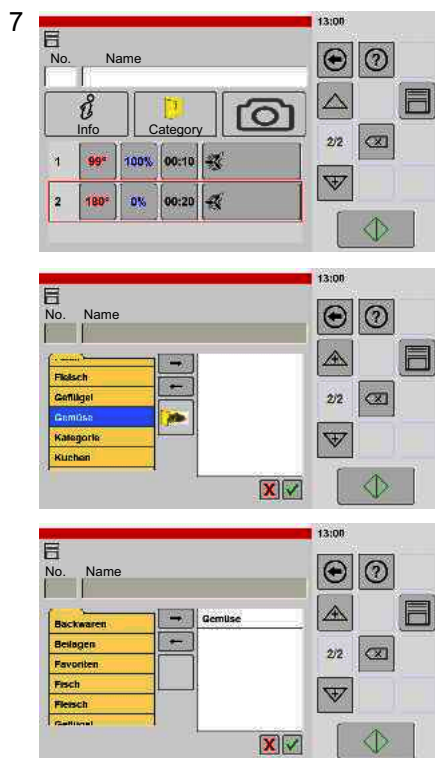

Assignment to categories and favourites



- ☞ Tap the "Categories" key.
- ☞ Tap the desired category, e.g. vegetables or "Favourites".
 - The category of "Favourites" is framed.



- ☞ Tap the key "Arrow".
 - The selected category or "Favourites" is moved from the left into the right field.
 - The product is now assigned to the selected category (e. g. vegetables) or "Favourites".
 - The product can be assigned to several categories. To this end, repeat the procedure for each individual category.



- ☞ Tap the "Confirm" button.

Key functions info:



Adding categories and favourites



Removing categories and favourites



Cancel



Confirm

8



Adding an image

Images for meals are already created as factory defaults.

If you would like to use your own images, you first have to import them into the memory.

To import digital photos, refer to Page 68 Figure 18



- ☞ Tap the "Camera" key.
- An overview of all existing images is displayed.

- ☞ Move the display, if necessary.

- ☞ Tap the desired image.
- The figure is framed.



- ☞ Tap the key "Add".
- The image is displayed above the Add key.



- ☞ Tap the key "Enter".
- The image has been assigned and the "Product entry" window is displayed.

Key functions info:



Add the selected image.



Confirm

9

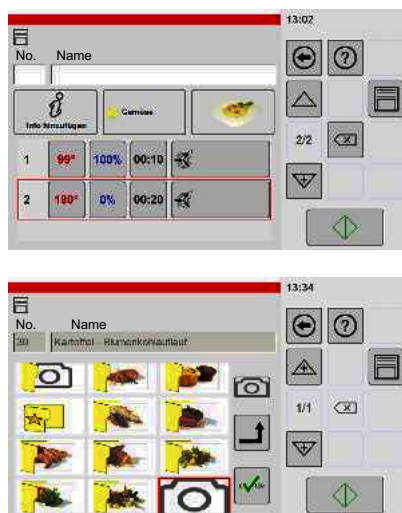

Removing the image



- ☞ Tap the image to be deleted.
- An overview of all existing images is displayed.

- ☞ Move the images displayed to the top until the "Camera" icon is displayed at the end.



- ☞ Tap the "Camera" key.
- The camera is framed.



- ☞ Tap the key "Add".
- The image is displayed above the Add key.



- ☞ Tap the key "Enter".
- The image has been assigned and the "Product entry" window is displayed.

Key functions info:



Add the selected image.



Confirm



Remove the image and allocate icon.



Storing the settings



- ☞ Tap the key "Save".
 - The product is stored in the cookbook and assigned to the allocated category of favourites.
 - The window for confirming the save process is displayed.



- ☞ Tap the key "Confirm".
 - The save process is completed.
 - The product can now be retrieved in the cookbook, the assigned category or in favourites.

Key functions info:



Saving in cookbook



Confirming the save process

7.2 Changing the settings of products in the cookbook



All settings stored in the cookbook can be adapted or changed, e.g.: Temperatures, times, favourite assignments, category assignments, cooking steps, etc.



Open the cookbook



- ☞ Tap the "Cookbook" key.
 - The "Cookbook" window will be displayed.



Selecting the product

- ☞ Tap the desired product.
 - The product is framed.
- ☞ Tap the "Cooking steps" key.
 - The "Settings" window will be displayed.

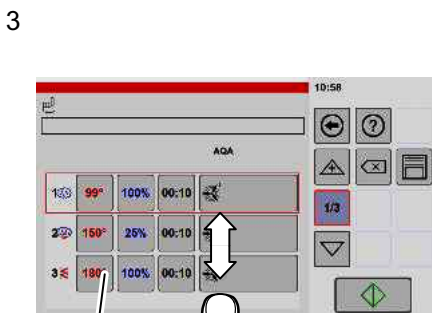

Display/change the cooking steps



- ☞ Tap the key "Cooking steps overview".
 - The "Cooking steps overview" window is displayed.

If more cooking steps are created than can be shown on the display screen:

- ☞ Tap the screen with finger and move the cooking steps displayed up or down.



- Each value displayed can be changed by tapping it.

Tap the value

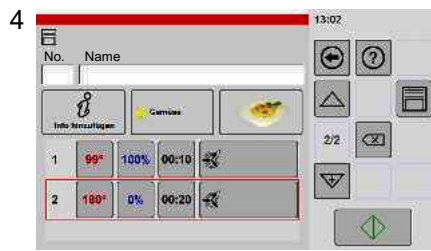

Changing the settings

Here changes can be made to No., Name, Info, Category/Favourites and Image.

For more details, refer to Page 45 from Figure 5.



Tap the key "Save".

- The changes are stored in the cookbook.
- The window for confirming the save process is displayed.

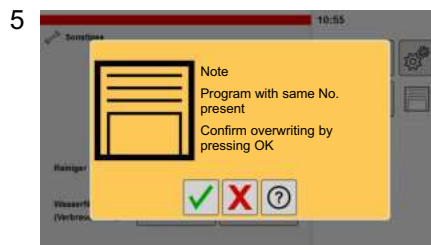

Confirming the save process



Tap the key "Confirm".

- The save process is completed.
- The product is changed.

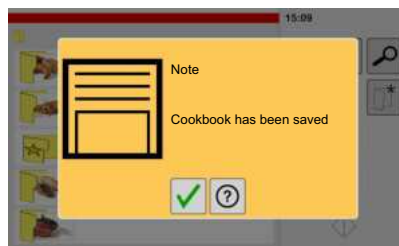

Tap the key "Confirm".

- The save process is completed.

7.3 Deleting a product from the cookbook



Open the cookbook



Tap the "Cookbook" key.

- The "Cookbook" window will be displayed.



Selecting and deleting the product

- ☞ Tap the product to be deleted.
 - The product is framed.



- ☞ Tap the "Delete" key.
 - A window for the security request is displayed.



- ☞ Tap the key "Confirm".
 - The window for confirming the save process is displayed.

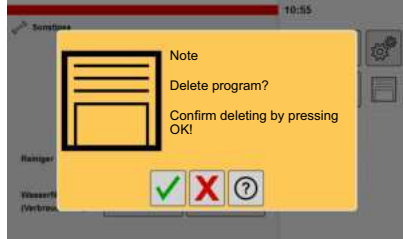

- ☞ Tap the key "Confirm".
 - The save process is completed.
 - The product is deleted.

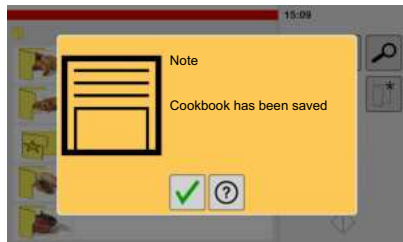

7.4 Creating and deleting a category



This function is a part of the cookbook.

7.4.1 Creating a category



Start categories



- ☞ Tap the "Category" key.
 - The "Categories" (product groups) list is displayed.



Creating a new category



- ☞ Tap the key "New category".
 - The input window is displayed.



Input the designation

☞ Input the designation for the category.



☞ Tap the key "Enter".

- An overview of all existing images is displayed.

Key functions info:



Switching the key assignment.



Move the cursor to the left or right.



Delete text from right to left.



Confirm



Cancel

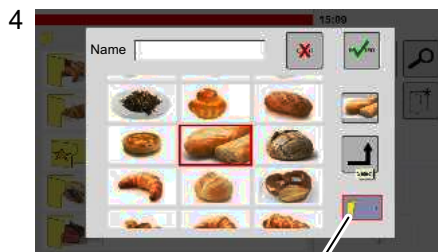

Switching off/on the category symbol

Image to add

☞ Move the display by tapping and moving up or down.

☞ Tap the image.

- The selected image is framed.



☞ Tap the key "Add".

- The image is displayed above the Add key.



☞ Tap the key "Enter".

- The window for confirming the save process is displayed.

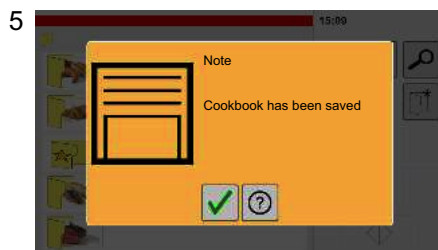

Saving



☞ Tap the key "Confirm".

- The category is saved in the cookbook.

Assigning products to a category, from Page 44Chapter 7.1 (Figure 7).

7.4.2 Delete category with products

Categories can only be deleted that are not allocated products.



Start categories



☞ Tap the "Category" key.

- The "Categories" (product groups) list is displayed.



Selecting the category

- ☞ Tap the category to be deleted.
 - The category is framed.
 - The key "Delete" is only active when the category contains no more products.



- ☞ Tap the key "Confirm".
 - The products allocated to this category are displayed.



Selecting the product

- ☞ Tap the product.
 - The product is framed.
- ☞ Tap the "Cooking steps" key.
 - The "Settings" window will be displayed.



Opening the window Categories/Favourites

- ☞ Tap the key "Category/Favourites".
 - The window for allocation is displayed.

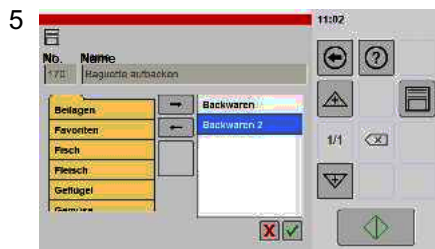

Select category and remove

- ☞ Tap the category to which the product is allocated.
 - The selected category is marked.
- ☞ Tap the key "Arrow".
 - The category is removed from the window and, thus, no longer allocated to the product.
- ☞ Tap the key "Confirm".
 - The "Settings" window will be displayed.
 - The category is removed from the display.



Category is removed

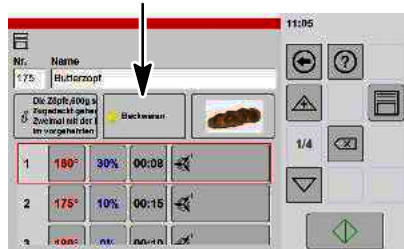

- ☞ Tap the key "Save".
 - The window for confirming the save process is displayed.

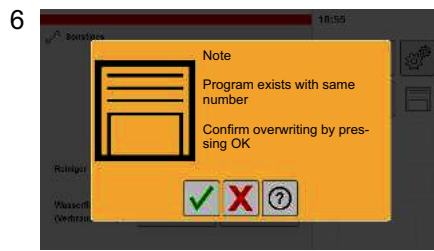

Saving the change



- ☞ Touch "Confirm".
- The allocation to the category is deleted in the cookbook.
- The window for confirming the save process is displayed.

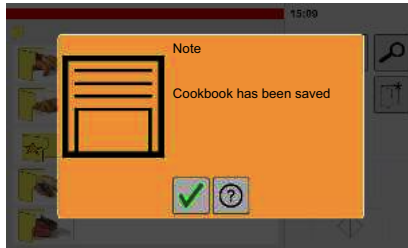

- ☞ Touch "Confirm".
 - The save process is complete.
- All products must be removed from the category.
To remove other products from the category:



- ☞ Touch "Back".
- Repeating the process, see from Figure 3 (page 52).



Delete category

- The key "Delete" is active when all allocations to the category are deleted.
- ☞ Tap the category to be deleted.
- The selected category is framed.



- ☞ Tap the "Delete" key.
- The window for confirming the save process is displayed.

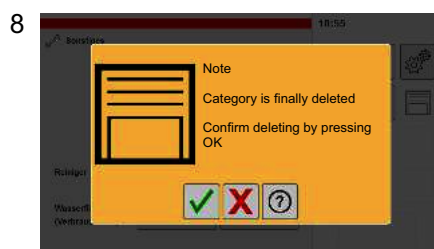

Saving the settings



- ☞ Tap the key "Confirm".
- The category is deleted.
- The window for confirming the save process is displayed.

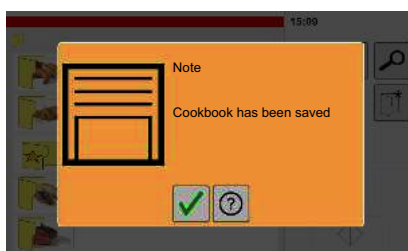

- ☞ Tap the key "Confirm".
- The save process is completed.
- The category is deleted.

8. Using baking

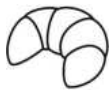

Select baking



- ☞ Tap the key "Baking".
- The window "Baking" is displayed.

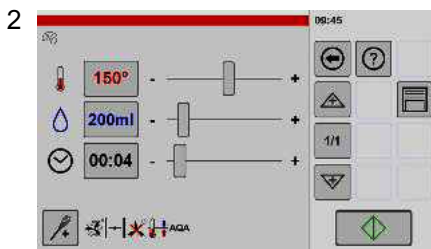

Start the baking process



- ☞ Tap the key "Start/Stop".
- The symbol in the "Start/Stop" key changes from green to red.
- Moisture is dosed into the cooking chamber (*refer to the following Figure 4!*)

Or set the additional functions:



- ☞ Tap the Auxiliary functions key.
- The window "Auxiliary functions" is displayed.



Change additional functions



- ☞ Tap the required "Auxiliary Functions".
- ☞ Confirm the set auxiliary function with "Enter".
- The window "Baking" is displayed.
- The auxiliary functions set are displayed in the window below.

Auxiliary functions window:

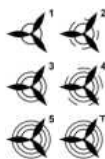

Ventilator speeds in five stages and cycled (T).

Select the desired ventilator speed by tapping the key several times until the desired ventilator speed is displayed.

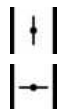

Supply air flap open.

Supply air flap closed.



Stationary times of the fan for exposure time of the moisture on the baking gears:

– short - 60 seconds



– medium - 120 seconds

– long - 180 seconds

– none



Signal and message window, output after expiry of the cooking step, e.g. for basting, seasoning or turning the food to be cooked. Has an effect on the signal, activated light signal and external signals.

  Start time/end of cooking preselection: Pre-select start or end of the cooking process. *Using start time, end of cooking, refer to page 27 Figure 8!*

Temp-Active: Preheating / Cooling before the cooking process.



- After a heating or cooling process the controller waits for an entry confirmation. Displayed by blue symbol in the key "Start/Stop".

Application "Cooling of the cooking chamber with cooking chamber door open" refer to page 22 chapter 5.7!



The cooking time countdown starts only after

- loading the cooking compartment, by opening and closing the door of the cooking compartment
- or
- after tapping the key "Start/Stop".

AQA Automatic Quantity Adaptation (quantity recognition and cooking time adaptation).



Closing the auxiliary functions window without confirming the change (Cancel).



Confirm settings and close window.

4 Window add moisture

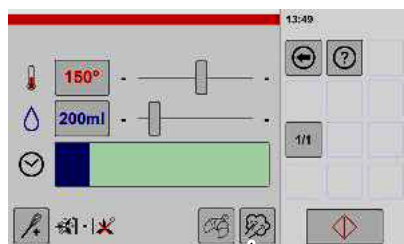

"Manual steam injection" button

Window add moisture

Adding moisture

- at the beginning of the baking process, e.g. setting 200 ml
- during the baking process using key "Manual steam injection"

Blue progress bar display

- from left to right - whilst adding moisture
- from right to left - during the stationary period of the motor

Preheating

- If preheating is enabled, after the preheating process has expired the cooking process must be started by loading or by pressing the key "Start/Stop".

5



Key "Rebaking"

Baking process window started

- The remaining time is displayed.
- The progress bar indicates the elapsed time graphically.
- The baking process can be interrupted by tapping the key "Start/Stop".
- During the baking process, it is not possible to set the moisture in in ml.

Setting the rebaking time



Tap the key "Rebaking".

- The baking time is increased by 1 minute.
- If more than one cooking step is created, the baking time is added to the last cooking step.
- The increased baking time is immediately applicable.
- The baking time can be increased by up to a total of 5 minutes.
- After tapping 6 times, the baking time returns to the initial time displayed.

9. Displaying HACCP protocols



HACCP is the abbreviation for Hazard Analysis Critical Control Points.

- The HACCP protocol is required in order to check the process characteristics.
- The protocols are a decisive means for the persons responsible to be able to verify that they have fulfilled their obligations.
- HACCP protocols are stored for 60 days. Once the 60 days have elapsed, the protocols are deleted automatically.

Setting output data for HACCP protocols, refer to Page 68 Figure 17!

Reading the data, refer to Page 68 Figure 19 (only possible with option USB connection!).



1 Displaying HACCP protocols



- ☞ Tap the key "HACCP".
- The window "HACCP" is displayed.

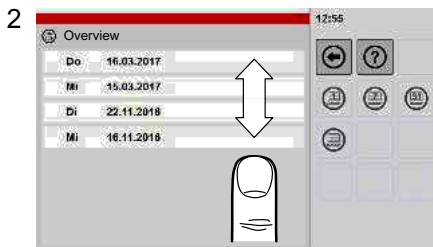

2 Moving the display



If more protocols are available than can be shown on the display screen:

- ☞ Tap the display screen with the finger and move the protocols displayed up or down.

- ☞ Tap the required date.
- The selection is framed.

Key functions info:



Display of day protocol selected



Active for appliances with USB connection.
Read-out of the day data, refer to Page 57 Chapter 9.1



Active for appliances with USB connection.
Read-out of the weeks data, refer to Page 57 Chapter 9.1



Active for appliances with USB connection.
Read-out of the month data, refer to Page 57 Chapter 9.1

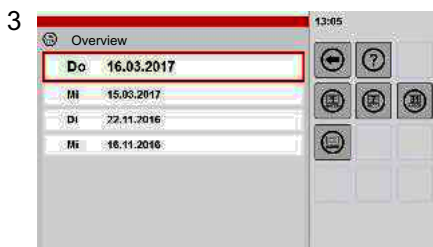

3 Select day

- ☞ Tap the required date.
- The selection is framed.



- ☞ Tap the key "Details".
- Data is displayed.

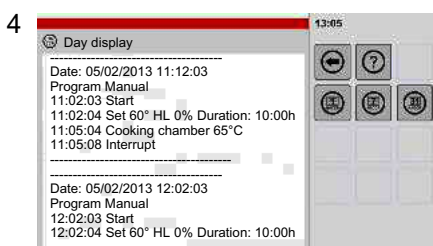

4 Moving the display

If more data is created than can be shown on the display screen:

- ☞ Tap the screen with finger and move the display up or down.

9.1 Reading HACCP protocols on a USB stick

Only possible with the option USB connection!

For USB flash drive requirements, see page 70 section 11.1.

1

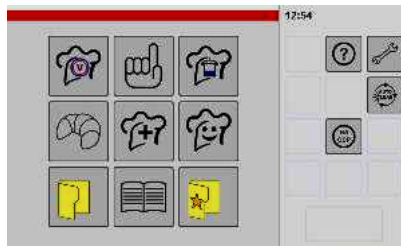

Start HACCP protocols



- ☞ Tap the key "HACCP".
- The window "HACCP" is displayed.

2

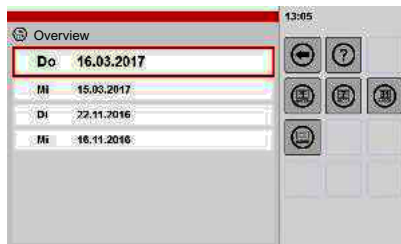

Select read-out date



Day

- ☞ Tap the required date from which the reading should be carried out backwards.
- The selection is framed.



Week

- ☞ Tap the key "Day/week or month data".



Month

- If identical data names exists on the USB stick, these are overwritten without warning.
- After writing the data, an instruction appears.



- ☞ Tap the key "Confirm".

- ☞ Remove USB stick.

 Appliance number: 999004
 Appliance type: E101SCRNFBUW
 Operating hours:
 Printing date: 06.02.12 10:05:48
 KT every 180s

Date: 05/02/2012
 Time: 22:02

Date: 05/02/2012 22:02:03
 Program Manual
 22:02:03 Start
 22:02:04 Set 60° HL 0% Duration: 10:00
 h
 22:05:04 Cooking chamber 65°C
 22:05:08 Interrupt

Info about the output data on the USB stick:

- A folder is created with the appliance serial number.
- The file name includes the output date.
- The file includes the appliance and cooking data (*refer to the example on the left*).

10. Setup of the control and user interface



All possible settings are shown in the following figures. Depending on the appliance equipment, several setup options have no function, e.g. presented grey and cannot be selected or the window is not displayed on the control panel.



Start Screen settings / Setup



If the "Setup" icon cannot be seen, tap and briefly hold the "Back" key.



The key display changes from "Return key" to "Home"

The start screen is displayed after the key is released.



Tap the "Settings/Setup" key.

The "Device data" window will be displayed.

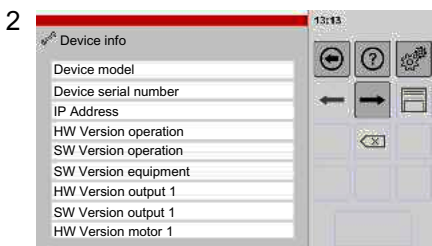

Displays device data

Here you can read the device data such as version number, installed options and free memory (Flash).



Tap the display screen with your finger and move the list up or down in order to see all information.



Continue to the next window - tap arrow key.

If the PIN (Personal Identification Number) is enabled, it is not possible to step forward and the PIN entry window appears.

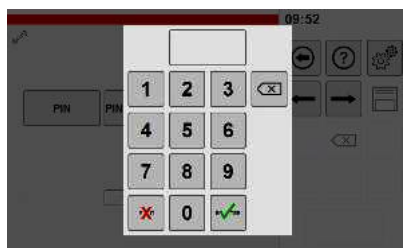

For information on entering or deleting the PIN, refer to Figure 10 and 11 in this chapter.

Key functions info:



Reset to factory start screen.



Accessing the help texts



Selection for authorised customer service



Step forward in display windows



Store the setting



Restore the settings

Information progress indication:

For example, whilst saving, exporting, importing

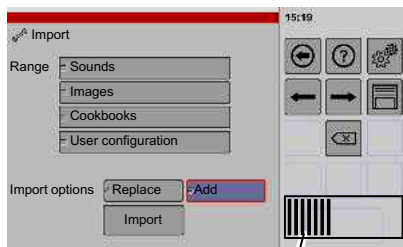

Progress indicator

3

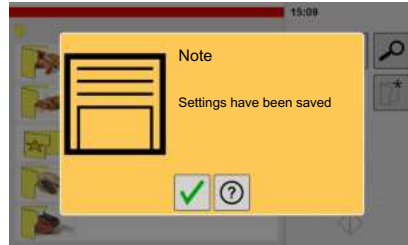
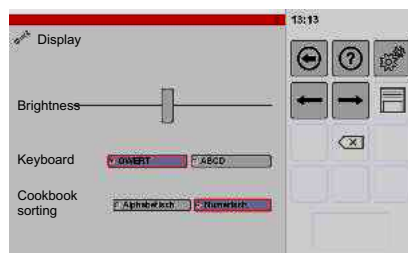

Setting the display for

- screen brightness
- allocating the keys to the keyboard
- cookbook sort order



☞ Setting screen brightness - Tap the slider control and move to the left or right.
 - Left = dark, right = bright

☞ Setting the allocation of keys to the keyboard - Tap desired display.
 - QWERT = typewriter / computer keyboard
 - ABCD = alphabetic key arrangement

☞ Setting the cookbook sort order - Tap desired display.
 - Alphabetic
 - Numeric



☞ Tap the "Save" key.
 • A note on the save process appears.



☞ Tap the key "Confirm".
 • The note disappears.



☞ Continue to the next window - tap arrow key.

4



Automatic screen sensitivity adjustment

Caution! Do not touch the control interface for 10 seconds during the automatic sensitivity adjustment, otherwise tapping the interface may result in errors.



☞ Tap the "Touch Auto Zero" button.
 • A note appears.
 • The sensitivity adjusts automatically.
 • The sensitivity adjustment is complete once the note disappears.



☞ Continue to the next window - tap arrow key.

5

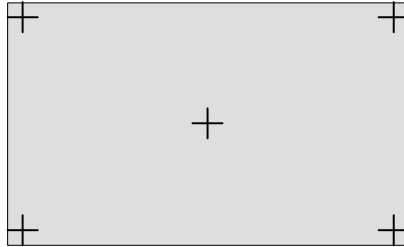
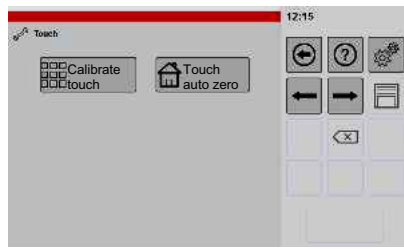

Calibrating/aligning the display

Caution! An incorrect calibration will result in an inability to work the buttons by tapping them! In that case, the calibration process must be carried out with a mouse! Connect the PC mouse via the USB connection and follow the on-screen instructions using the cursor. The mouse connected is only recognized after the appliance is restarted (USB connection optional).



Tap the key "Touch calibration".

- A window with a crosshair in the centre is displayed.
- Important, only tap the crosshairs. Do not touch the clear area, otherwise malfunctions occur.



Tap the crosshair.

- The crosshair switches to the lower right corner.

Tap the crosshair.

- The crosshair switches to the next corner.

Tap the crosshair until all corners have been confirmed.

- A note on the save process appears.



Tap the key "Confirm".

- The note disappears.

- Calibration is completed.



Continue to the next window - tap arrow key.

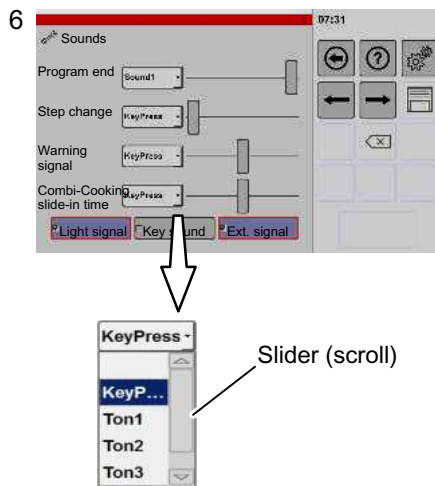

Setting the acoustic signals (tones)

Several sound files are included as factory default. These can be used for a variety of messages in different ways.



Turn the volume up so that a the selected sound can be heard when a sound file is selected.

- Slider control: left quiet - right loud.



Tap arrow key.

- The available files are displayed.



- A scrollbar will be shown if there are a large number of files available.

Tap the arrows or the scrollbar and move it until the desired file is visible.

Tap the desired selection.

- An acoustic signal is heard.



Tap the "Save" key.

- A note on the save process appears.



Tap the key "Confirm".

- The note disappears.



Continue to the next window - tap arrow key.

Info on settings options:

Program end: signal sounds at the end of the cooking process.

Step change: In cooking programmes with different modes, a signal sounds before switching to the next mode.

Warning signal: When notices with red or yellow background appear on screen.

Combi-Cooking slide-in time: Signal sounds when a slide-in time expires.

Light signal: Cooking chamber lighting illuminates when light signal is activated.

Key sound: Sound when tapping keys.

External signal: External speaker or even light outside the device (has to be installed on-site by the customer).

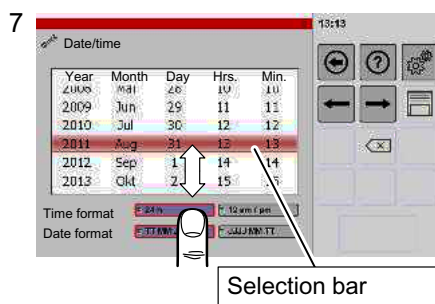

Setting the date and time

- These values are arranged in columns.



Tap the column to be changed and move until the desired value appears in the selection bar.

Time format - Tap desired display

- 24 h
- 12 am / pm

Date format - Tap desired display

- Day-Month-Year
- Year-Month-Day



Tap the "Save" key.

- A note on the save process appears.



Tap the key "Confirm".

- The note disappears.



Continue to the next window - tap arrow key.

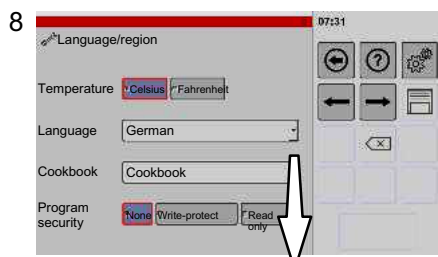

Slider (scroll)

Adjusting the language/region and program security



- Tap arrow key (e.g. language or cookbook).
- The available files are displayed.



- A scrollbar will be shown if there are a large number of files available.

- Tap the arrow or the scrollbar and move it until the desired file is visible.

- Tap the desired selection.

- An acoustic signal is heard.



- Tap the "Save" key.
- A note on the save process appears.



- Tap the key "Confirm".

- The note disappears.



- Continue to the next window - tap arrow key.

Info on settings options:

- Temperature in Celsius or Fahrenheit
- Language: Language setting for the control and display panel
- Cookbook: Cookbook selection
- Program protection for cookbook
 - **None:** Changes and additions to the cookbook are possible.
 - **Write protected:** Settings can only be made for the current cooking process. The settings cannot be saved.
 - **Read only:** The cookbook can be used. However, no settings can be changed for the current cooking process.

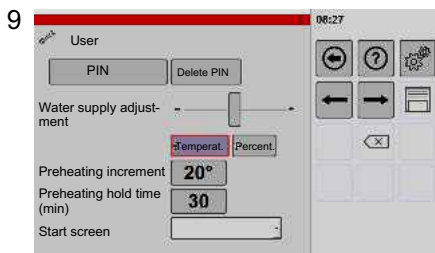

Adjusting the preheating process

- ☞ Tap the desired increment type "Temperature or percent"
 - The selected unit is displayed.
- ☞ Tap the value in the "Preheating increment" or "Preheating hold time" box.
 - The numeric keyboard is displayed.
- ☞ Enter value.
- ☞ Tap the key "Confirm".
 - The value is changed.
- ☞ Tap the "Save" key.
 - A note on the save process appears.
- ☞ Tap the key "Confirm".
 - The note disappears.
- You can now step forward to the next screen.

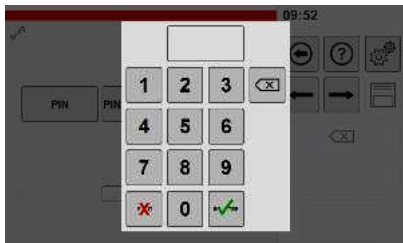

Info on settings options:

Water supply adjustment: Humidification of the cooking chamber - Different water supply pressures can be allowed for with this setting option.

Temperature or percent

Preheating increment: Automatic increase for the preheating process.

Preheating hold time (min): If the target temperature has been reached, this is held for the set time.

PIN - refer to Figure 10 and 11!

Start screen - refer to Figure 12!

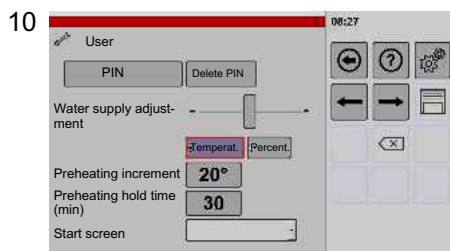

Enabling the PIN / Restricting modification permissions

If you want to allow only certain people to change settings, you can block access by entering a PIN.

No PIN (Personal Identification Number) is set by factory default.

If you have forgotten the PIN it can only be unlocked by authorised customer service.

- PIN** ☞ Tap the "PIN" key.
 - The numeric keyboard is displayed.
- ☞ Enter 4-digit PIN.
- ☞ Tap the "Enter" button.
 - You are prompted to enter the same PIN once more.
- PIN** ☞ Enter PIN again.
- ☞ Tap the "Enter" button.
- ☞ Tap the key "Save".
 - A note on the save process appears.
- ☞ Tap the key "Confirm".
 - The note disappears.
- You can now step forward to the next screen.

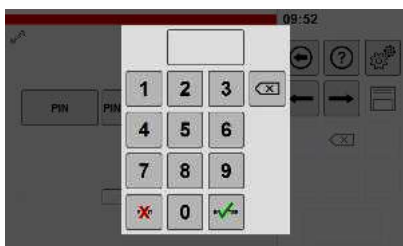

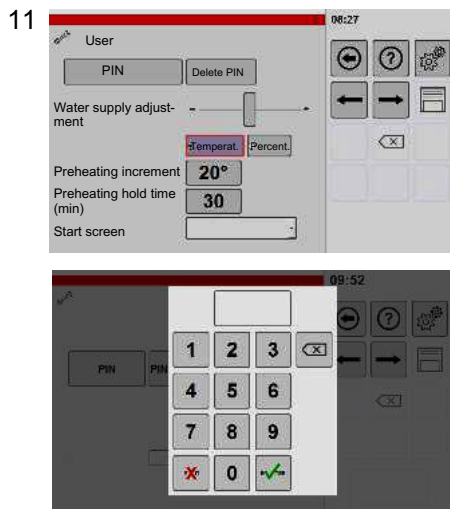

Disabling/deleting the PIN

This function is used to delete a previously saved PIN. The delete process is necessary for example, if a new PIN is to be created, or the limitation on modification permissions is to be lifted.

- Tap the "Delete PIN" key.
 - The "Save" key changes from light grey to black.
 - If no PIN has been created, the light grey colour of the "Save" key does not change.
- Tap the "Save" key.
 - A note on the save process appears.
- Tap the key "Confirm".
 - The note disappears.
 - The restrictions have now been lifted.

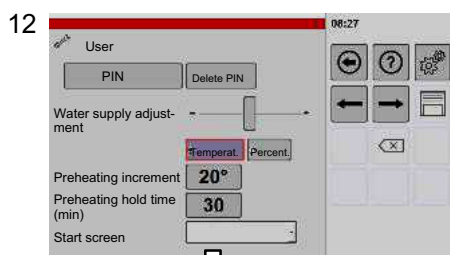

Example display:
"Manual" mode



Setting the start screen

This setting can be used to specify which screen should be displayed after the device is turned on.

- Tap the box or arrow key.
 - The available screen options are displayed.
- Tap the arrows or the scrollbar and move it until the desired selection is visible.
- Tap the desired selection.
 - The selection is shown in the box.
- Tap the "Save" key.
 - A note on the save process appears.
 - The selected screen is saved and will be displayed the next time the device is turned back on.
- Tap the "Confirm" button.
 - The note disappears.
- Step forward to the next window - tap key.

Info on selection options:

Figure 13 Standard = the display shown in the following figure 13 has been selected.

Figure 12 Manual - the operating modes are displayed after switching on.

 The content of the cook book is displayed after switching on.

 The created categories are displayed after switching on.

 The created favourites are displayed after switching on.

 The cooking processes are displayed after switching on.

 The symbols for vitalising are displayed after switching on.

 The symbol for special programs is displayed after switching on.

 The symbols for SmartCooking are displayed after switching on.

 The symbol for baking is displayed after switching on.

13



This selection results in the following screen



Setup the home screen / Allocating and arranging functions on the display window

This setting can be used to specify which functions should be displayed in the display area, and whereabouts.

The specifications set here are displayed after the Home key is tapped.



- ☞ Tap the box or arrow key.
 - The available screen options are displayed.



- ☞ Tap the arrows or the scrollbar and move it until the desired selection is visible.

- ☞ Tap the desired selection.
 - The selection is shown in the box.



- ☞ Tap the "Save" key.
 - A note on the save process appears.



- ☞ Tap the key "Confirm".
 - The note disappears.



- ☞ Step forward to the next window - tap key

Info on selection options:

blank = nothing displayed



Manual - this symbol is displayed.



Cookbook - this symbol is displayed.



Categories - this symbol is displayed.



Favourites - this symbol is displayed.



Cooking process - this symbol is displayed.



Vitalising - this symbol is displayed.



Special programs - this symbol is displayed.



SmartCooking - this symbol is displayed.



Baking - this symbol is displayed.

14

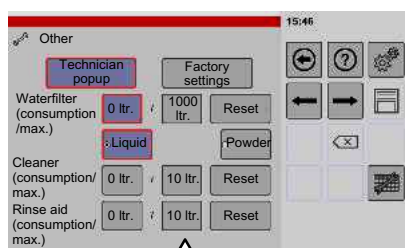

Setting consumption max.
(Figure software version 0.26.4.9 / 27.7.7)



Reset to factory settings

Settings that have been made by the user are reset, e.g. cookbook and user settings. As a precaution, save the user settings to a USB stick. *Data export refer to Page 68 Figure 19* (USB connection optional).

- ☞ Tap the key "Factory settings".
 - A warning message will be displayed.
- ☞ Tap "Confirm" or "Cancel".
- ☞ Wait until the messages goes off and you are prompted to switch the unit off and on.
- ☞ Turn the appliance off and on.
 - Observe approx. 30 seconds waiting time between switching off and on.

Info about other setting options:

Technician popup: Refer to the following Figure 15!

Cleaner: For appliances with an automatic cleaning system, selection of powder or liquid cleaning.

Water-filter counter status: Factory default, can be set using the numeric keypad. If "0" is entered, no message appears.

15

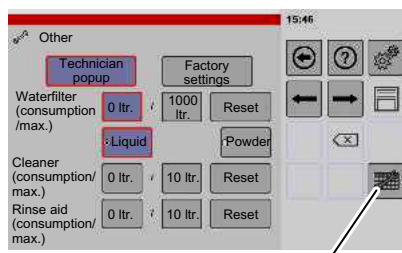

Key "Technician popup"

Enable function "Technician popup"

The expired appliance activities are displayed in the window "Technician popup". This display can be used for fault diagnosis.

In order to make the Technician popup visible and mask it during operation, the key "Technician popup" must be activated.

After switching off the appliance and on again, the key "Technician popup" is disabled.

Technician popup

Activating the key "Technician popup"

- ☞ Tap the switch "Technician popup".
- The key "Technician popup" is displayed.

Show "Technician popup"



- ☞ Tap the key "Technician popup".
- The window "Technician popup" is displayed.
- The actual status of the appliance is displayed.

Updating the display

- ☞ Tap the key "Refresh".
- Status of the appliance is updated in "Technician popup".
- In order to obtain realtime updating, tap and press the Refresh key.



Mask "Technician popup"

- ☞ Tap the key "Technician popup" or arbitrary adjacent to it.
- By tapping the key "Technician popup", the display disappears.
- By tapping arbitrary adjacent to "Technician popup", the "Technician popup" is masked to the rear. To superimpose, tap twice on "Technician popup".

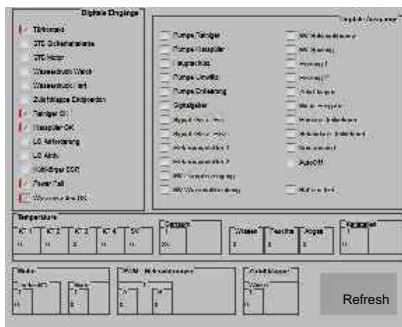

16



Switching the pull-out shower on/off

If the pull-out shower is leaking, it can be switched off with this function.

- ☞ Tap the "Pull-out shower" key.
- Red frame, indicates pull-out shower is switched on.
- ☞ Tap the "Save" key.
- A note on the save process appears.

17 Setup the HACCP protocols

HACCP is the abbreviation for Hazard Analysis Critical Control Points.

HACCP protocols are stored for 60 days. Once the 60 days have elapsed, the protocols are deleted automatically.

Reading the data, refer to Page 68 Figure 19 (only possible with option USB connection!)

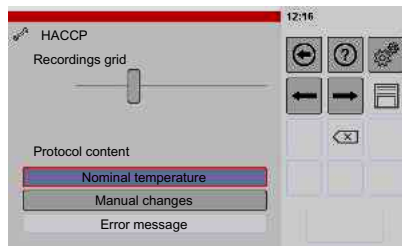

☞ Setting the grid in seconds for recordings - tap the slide control, and push to the left or right.

- The set value is displayed in seconds.
- ☞ Tap the required additional type of saving.
- The selected memory type is highlighted in colour and framed.



☞ Tap the "Save" key.

- A note on the save process appears.



☞ Tap the key "Confirm".

- The note disappears.



☞ Step forward to the next window - tap button.

Info about additional selection options:

Protocol content:

- Nominal temperature
- Manual changes
- Error messages

18

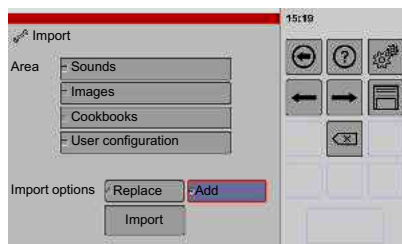

Data import – USB stick -> control unit

This function enables cookbooks or image/sound files, for example, to be added.

Exporting and importing data see page 69 Chapter 11./Importing 11.5

19



Data export – control unit -> USB stick

Use this function, for example, to save your settings. You can use this data, for example, for restoring user settings, image and sound files, and cookbooks.

Exporting and importing data see page 69 Chapter 11./Exporting 11.4

20

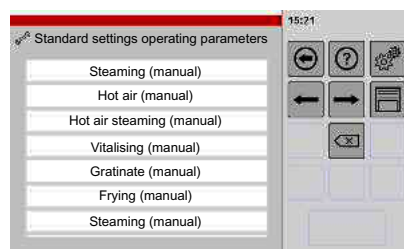

Setting standard cooking data

Here you can adapt cooking data to your own operational conditions. These are shown after the relevant operating mode, cooking process, or the special programme is selected.



- ☞ Touch the display screen with your finger and drag the list up or down to see all information.

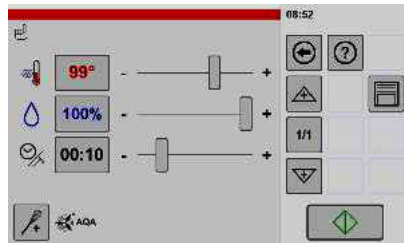

- ☞ Tap the desired setting option.
 - The "Settings" window appears.
- ☞ Set up the desired standard cooking data.



- ☞ Tap the "Save" key.
 - A note on the save process appears.



- ☞ Tap the key "Confirm".
 - The note disappears.

Info on operating modes / cooking processes / special programmes

For example, Steaming, Hot air, Hot air steaming, Vitalising, Gratinating, Frying, Grilling, Stewing, Braising, Defrosting, Poaching, Delta-T, NT cooking, Gentle roasting, Cook & Hold, Slide-in times, Sous-Vide.

21



Input mask for remote maintenance (optional)

This function is only intended for authorised customer service personnel!

A remote connection to the factory can be initiated if remote maintenance is required.

The appliance must be connected using a CAT5 cable to a router with internet connection.

11. Exporting and importing data

This function allows you, for example, to save appliance data, add cookbooks or image/sound files or to standardize cookbooks for all appliances.

Only possible with USB connection/USB activation option!

(USB stick = removable storage device, USB = Universal Serial Bus)

Important: save the appliance data before an import (data export)!

- You can achieve the required data structure by means of a data export
 - Data structure, see next chapter 11.2
 - Exporting data - example: saving data, see page73 Chapter 11.4
- You can modify the exported data according to your requirements and reuse the data for a data import.

11.1 Requirements for USB data storage media (USB flash drive)

(USB flash drive = removable storage device, USB = Universal Serial Bus)

Formatting:



The USB drive has to support USB 2.0.

Up to 64 GB

- Formatting the USB flash drive:
file system = FAT32/FAT32 (standard)
- Size of allocation units = 32 kB

64 GB and higher

- Formatting the USB flash drive:
file system = exFAT
- Size of allocation units = 128 kB

Info

The USB flash drive can contain data. A new directory is created during the export process.

Connection USB ports

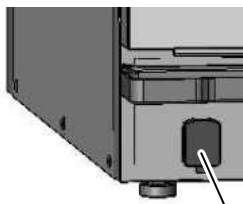

Type: T

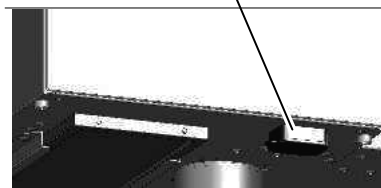

Type QT

Type: 2011/2021

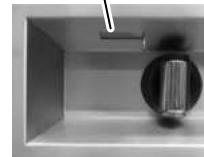

USB extension cable

For special formats of USB sticks, which cannot be inserted into the USB port, use the USB extension cable with type A plug as an adapter.

11.2 Data export: information about the data structure on the USB stick

- Depending on the relevant number of selected areas, for example cookbooks, sounds or images, only the corresponding folders for these areas, e.g. "cookbooks", "pictograms", "sounds" are copied to the USB stick.
- File names must not contain umlauts or special characters, for example ä, ö, ü, *, /, etc.

Folder	Folder/file	Files	Notes/requirements for files
CS_DATA	cookbooks	COOKBOOK.XML Kochbuch_DE.xml cookbook_EN.xml etc.	<ul style="list-style-type: none"> • Number of visible characters in menu: 20 characters.
	pictograms	0100_kalbshackse.png 0200_gaensebrust.png 0200_haehnchen.png etc.	<ul style="list-style-type: none"> • Image file formats jpg or png. • Image size for reading, maximum 2 Mbyte. • The appliance software converts the imported image files: size 480x270 pixels, resolution 72 pixels per inch, pixel depth 24, 16 million colours.
	sounds	Beep.wav Flipper.wav Klingel.wav etc.	<ul style="list-style-type: none"> • Sound format wav, e.g. mobile ring tones or PC sound files can be used. • File names: maximum 30 characters. • Number of visible characters in menu: 10 characters. • Length of sound file maximum 20 seconds, audio format PCM, sampling rate 11/22/44 kHz, quantisation 16 bit, channels 1 or 2 (mono/ stereo).
	userconfigmain.cfg specialpreps.xml		<ul style="list-style-type: none"> • These files contain the saved user settings. • Attention: do not change the file content, otherwise malfunction!

11.3 Data import: information about the "Replace/Add" option

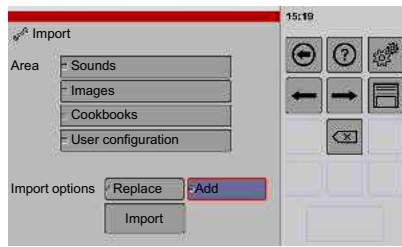

When you call up the menu, "Add" is enabled.

Attention: with the "Replace" function, the folder content is first deleted, then data is copied from the USB stick.

Function	"Replace" means:	"Add" means:
	<p>1. All files in the relevant folder of the control unit are deleted.</p> <p>2. The files from the USB stick are copied to the relevant folder.</p> <p>Caution! Example: if the control unit contains three cookbooks, but there is only one cookbook on the USB stick, the "Replace" function will only copy one cookbook to the control unit. This means that the control unit will contain only one cookbook.</p> <p>Should be used if you want to standardize data across all appliances (e.g. standardize cookbooks in all appliances).</p>	<p>Add files.</p> <p>When to use Should be used if you want to add data with a new file name.</p>
Sounds	<p>1. Attention! All existing sounds in the "sounds" folder will be deleted.</p> <p>2. The sounds on the USB stick are copied to the "sounds" folder.</p>	<p>Sounds with different file names are added to the "sounds" folder.</p> <p>Sounds with identical file names are not changed.</p>
Images	<p>1. Attention! All existing images in the "pictograms" folder will be deleted.</p> <p>2. The images on the USB stick are copied to the "pictograms" folder.</p>	<p>Images with different file names are added to the "pictograms" folder.</p> <p>Images with identical file names are not changed.</p>
Cookbooks	<p>1. Attention! All existing cookbooks in the "cookbooks" folder will be deleted.</p> <p>2. The cookbooks on the USB stick are copied to the "cookbooks" folder.</p>	<p>Cookbooks with different file names are added to the "cookbooks" folder.</p> <p>Cookbooks with identical file names are not changed or overwritten.</p> <p>Example: The cookbook "Kochbuch_DE" exists. To add "cookbook_EN", the correct import function in this case is "Add".</p>
User configuration	<p>The "userconfigmain.cfg" and "special-preps.xml" files are overwritten.</p> <p>The appliance must be restarted to activate the new user configuration.</p>	<p>No function!</p>

11.4 Exporting data - example: saving data

Examples of using exported data:

- To back up sounds, images, cookbooks and the user configuration.
- To import into other appliances for standardized user interfaces within a company.



Start screen settings/setup



☞ If the "Setup" icon cannot be seen, tap and briefly hold the "Back" key.



- The key display changes from "Back" to "Home"
- The start screen is displayed when the key is released.



☞ Touch "Settings/Setup".

- The "Appliance Data" window is displayed.



☞ Continue to the next window - tap arrow key.

- If the PIN (Personal Identification Number) is enabled, it is not possible to continue and the PIN entry window appears.

For information on entering or deleting the PIN, see Figures 63 and 10 from page 11.

☞ Keep tapping the arrow key until the "Export" window appears.



Progress indicator

Data export: control unit -> USB stick



Export

☞ Insert USB stick into the USB port.

Connecting the USB stick, see page 68 Figure 18

- Wait approx. 5 seconds for the control unit to establish a link with the USB stick.

☞ Tap on the data selected for export.

- The selected data type is highlighted in colour and framed.



☞ Tap "Export".

- The copying process is carried out (takes approx. 5 to 30 seconds depending on the amount of data).
- A message appears after completion.



☞ Touch "Confirm".

- The message disappears.

☞ Detach the USB stick.

☞ To back up the exported data, copy it from the USB stick to a PC or laptop!

- Creating a copy backs up the data. You can use this data again if required.

11.5 Importing data - example: replacing a cookbook/cookbooks

Use this function, for example, to standardize cookbooks across multiple appliances.

Before replacing data, export the existing data to a separate USB stick as a precaution (*exporting, see Chapter 11.4*)

Requirements for data import, see page 71 Chapter 11.2

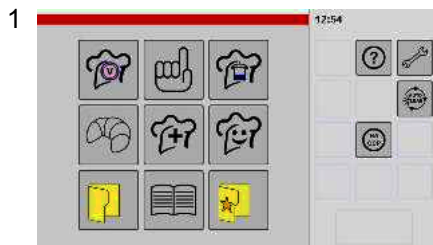

Start screen settings/setup



☞ If the "Setup" icon cannot be seen, tap and briefly hold the "Back" key.



- The key display changes from "Back" to "Home"
- The start screen is displayed when the key is released.



☞ Touch "Settings/Setup".

- The "Appliance Data" window is displayed.



☞ Continue to the next window - tap arrow key.

- If the PIN (Personal Identification Number) is enabled, it is not possible to continue and the PIN entry window appears.

For information on entering or deleting the PIN, see Figures 63 and 10 from page 11.

☞ Keep tapping the arrow key until the "Import" window appears.

- The "Add" key is highlighted in colour and framed.

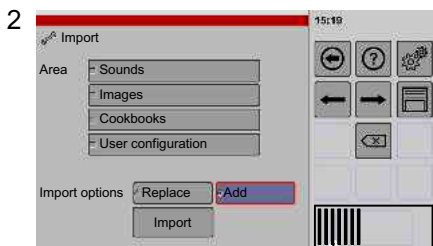

Progress indicator

Data import: USB stick -> control unit



Importing (example: replacing all cookbooks in the control unit)

☞ Insert USB stick into the USB port.

Connecting the USB stick, see page 68 Figure 18

- Wait approx. 5 seconds for the control unit to establish a link with the USB stick.

• Attention: the "Replace" function deletes existing data! *Observe the information in Chapter 11.3!*

☞ Tap on data required for import e.g. cookbook.

- The selected data type is highlighted in colour and framed.



☞ Touch "Replace".

- The "Replace" key is highlighted in colour and framed.



☞ Tap "Import".

- The copying process is carried out (takes approx. 5 to 30 seconds depending on the amount of data).
- A message appears after completion.





☞ Touch "Confirm".

- The message disappears.
- The data has been read into the control unit.
- The imported data is not available until after the appliance has been restarted.
- Activate the newly imported cookbook after the restart: Select and save the new cookbook in the controller, see Page 62 Figure 8!

12. Completion of operation

☞ Cleaning the appliance (See the following 13. "Cleaning and Care" chapter.

The appliance is equipped with different main switches, depending on the type of appliance and year of manufacture:

 Touch-key with LED indicator light	 Switch with LED ring indicator light
<p>☞ Switch on the appliance - tap the key "On/Off".</p> <ul style="list-style-type: none"> • The cooking chamber lighting and the screen display are switched off. • The red indicator light (LED) in the key "On/Of" illuminates (standby). 	<p>☞ Switch off the appliance - tap the key "On/Off".</p> <ul style="list-style-type: none"> • The cooking chamber lighting and the screen display are switched off. • The LED ring indicator light goes off (standby).

- The appliance still carries voltage.

☞ Turn off the building's mains switch.

☞ Turn off the water tap.

13. Cleaning and Care

13.1 Notes on stainless steel (risk of corrosion!)

- Please note! Even high-quality stainless steel can corrode if handled improperly. Salt, acids, chlorine, iodine and food residues destroy the protective coating and can cause even high-quality stainless steel to corrode e.g. lead to pitting damage!
- The stainless steel surface creates a new protective layer immediately after damage, but only if air or oxygen-rich water has time to react with the surface.
- If the cooking chamber has not been cleaned carefully, residues such as limescale, proteins or starch remain. If these residues are not completely removed, it prevents air or oxygen-rich water from getting to the stainless steel surface. A protective coating cannot be formed and this causes corrosion e.g. pitting damage, even on high-quality steel. Therefore, clean thoroughly to prevent residues from sticking.
- For example, if only non-fatty foods are cooked with the cooking method steaming, this can damage the stainless steel surface over time. Therefore, also regularly cook with fatty food or protect the cooking chamber and attachment parts against corrosion by applying cooking oil or cream cleaner, refer to Page 87 Chapter 13.7!

13.1.1 Secondary cleaning after completion of automatic cleaning (liquid/powder cleaner)

Automatic cleaning is designed to dissolve and remove as much contamination as possible in the cooking chamber and on built-in parts, e.g. on air baffles and racks.

However, there may still be stubborn residual contamination in the cooking chamber, as well as contamination in hard-to-reach places, e.g. on the support rails of the racks.

This residual contamination should be completely removed manually as soon as possible after the end of automatic cleaning.

If this contamination is not removed, the protective coating on the stainless steel may become damaged, which may lead to corrosion. The manufacturer shall not assume any liability for this.

13.2 Notes on cleaning



- Clean the appliance / cooking chamber **a minimum of once a day**, depending on the level of soiling. Here, use the cleaning program of the appliance, e.g. option Autoclean!
- Also if only cooking in steaming mode, the cooking chamber must be cleaned **a minimum of once a day** using the cleaning program.
- For extended operating breaks during which the appliance cools down, clean the cooking chamber after use (risk of clogging through solidifying grease or firmly adhering, drying residues)!
- Keep caustic cleaners away from the control panel!
- Do not use abrasive cleaning agents!
- Do not use any sharp or pointed objects for cleaning!
- Do not clean the appliance with acids as this may damage the stainless steel surfaces.
- Manual cleaning: Once automatic cleaning is complete, switch off the appliance and disconnect it from the mains. For manual cleaning, e.g. to clean the enclosure, turn off the mains switch and disconnect the mains plug!
- Do not spray or clean the appliance with water jets, water hoses, high-pressure cleaners, high-pressure steam cleaners or steam cleaners!
- Stainless steel must not be in prolonged contact with concentrated acids, vinegar essence, salt solution, mustard or spice mixtures; otherwise the protective layer will be attacked. After use, clean and rub dry stainless steel surfaces.
- Follow the instructions of the cleaning product manufacturer.
- Suitable cleaning and care products can be obtained from your authorised Customer Service agent.
- The device manufacturer is not liable for any damage that has been caused as a result of improper cleaning or the use of incorrect cleaning agents.
- An automatic rinse process must be started if the automatic cleaning of the cooking chamber was interrupted (e.g. power failure).
- Stainless steel surfaces are attacked through use, therefore, protect the cooking chamber and installation parts against corrosion, e.g. using cooking oil or cream cleaner. Refer to instructions, Page 87 Chapter 13.7

13.3 Preparing the appliance for cleaning of the cooking chamber



CAUTION Risk of burning! Wear protective gloves and protective clothing!

- ☞ If the cooking chamber is still hot, open the cooking chamber door and allow the cooking chamber to cool to approx. 60°C.
- ☞ **Remove containers, grilles, sheets from the cooking chamber.**
- ☞ Check and clean the water manifold (*see page 77 Chapter 13.3.1*).
- ☞ Remove residual food from the cooking chamber.
- ☞ Clean the outlet screen (*see page 77 Chapter 13.3.2*).
- ☞ Hook in the removable racks or push in empty rack trolley.
- ☞ Insert the core temperature sensor into the holder.
- ☞ **In case of extreme soiling, soak the dried/baked on residues with special spray cleaner for cooking chambers.**
- ☞ Only for appliances with liquid cleaning system: Check if sufficient cleaning agent is available and the suction hoses are immersed in the cleaning agent.

13.3.1 Cleaning the water manifold



CAUTION Risk of burning! Wear protective gloves and protective clothing!

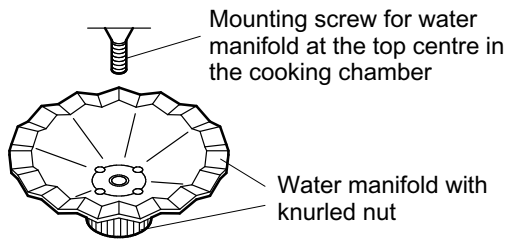

- The water manifold must be cleaned before starting the automatic cleaning process!
- ☞ Release and remove the knurled screw on the water manifold by turning it anticlockwise.
- ☞ After cleaning, fully tighten the water manifold by hand.

13.3.2 Cleaning the outlet screen in the cooking chamber drain



CAUTION! Risk of burning! Wear protective gloves and protective clothing!

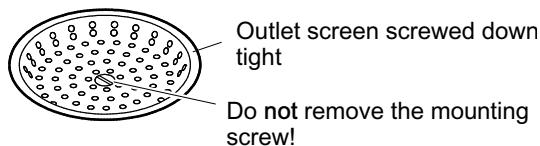

- ☞ Remove food residues from the cooking chamber and outlet screen to allow the water to drain during automatic cleaning.
- **Attention!** Do not remove the mounting screw in the outlet screen! The outlet screen may only be removed by the authorised Customer Service for maintenance tasks!

13.3.3 Using the sealing plate Type 2011/2021



Caution, risk due to bruising on the feet! Before unlocking or swivelling the sealing plate downwards, remove the sealing plate from the swivel area. With the right foot, activate the unlocking lever!

The sealing plate is required in order to completely close the cooking chamber,

- if the appliance is operated without rack trolley (e.g. for preheating),
- for automatic cleaning without rack trolley pushed in.

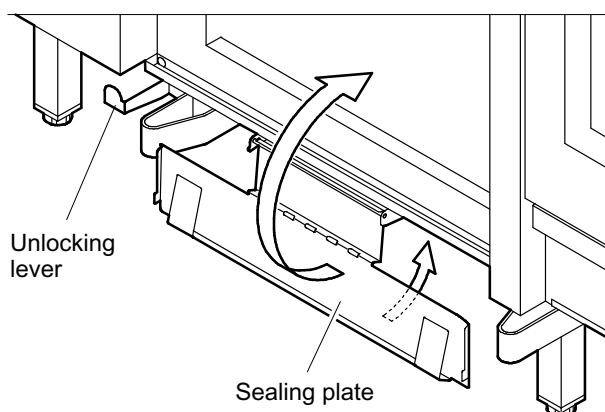

Engaging of the sealing plate

- ☞ Swivel the sealing plate to the rear and upwards until it automatically engages.

Using the sealing plate

- Caution, sealing plate automatically swivels out!
- Make sure that no persons are in the swivel area of the sealing plate.
- ☞ With the right foot, push the unlocking lever upwards.
- The sealing plate swivels downwards.
- ☞ Raise the sealing plate and swivel towards the cooking chamber.

13.4 Cleaning the cooking chamber - without automatic cleaning system

If no automatic cleaning system is in place or if it is defective, the cooking chamber must be cleaned as follows.



- **WARNING! Caustic substances!** Wear safety goggles, protective gloves and protective clothing when handling cleaning and rinse-aid products.
- Only use cleaning agents that are manufactured for these appliances and purposes and which have been recommended by the appliance manufacturer. Unsuitable cleaners may cause corrosion damage on stainless steel surfaces and damages to gaskets and components.
- The device manufacturer is not liable for any damage that has been caused as a result of improper cleaning or the use of incorrect cleaning agents.

- ☞ Preparing the appliance for cleaning the cooking chamber (refer to Page 76 Chapter 13.3).
- ☞ We recommend opening the cooking chamber door for about 5 to 10 minutes to shorten the automatic cool-down process at very high temperatures (more than 180°C).



Start the semi-automatic cleaning



- ☞ Tap the "AutoClean" (automatic cleaning) key.
 - The "Cleaning" window will be displayed.



Selecting the cleaning program



- ☞ Tap the cleaning level "Manual cleaning".
 - The "Manual cleaning" window will be displayed.



Key function info (for manual cleaning):



Manual cleaning - duration approx. 20 minutes (without cooling or heating process)



Starting the cleaning process



- ☞ Tap the "Start/Stop" key.
 - A cooling or heating process takes place if the temperature in the cooking chamber is too high or too low.
 - Duration of the automatic cool-down until cleaning commences: At cooking chamber temperatures
 - 150°C = approx. 6 Minuten,
 - 180°C = approx. 10 Minuten,
 - 250°C = approx. 30 Minuten.
 - After automatic temperature adjustment, the soaking process automatically starts.
 - The progress bar indicates the time progression of the process.

After the soaking process is finished, the message "Spray cleaner" appears.

Introducing the spray cleaner

- ☞ Put on safety goggles, protective gloves and protective clothing.
- ☞ Spray the cooking chamber with special spray cleaner for cooking chambers.
- ☞ Close the cooking chamber door.
 - The information "Start cleaning process?" appears.



- ☞ Tap the key "Confirm".
 - The cleaning continues.

After the cleaning is finished, the information "Rinse cooking chamber" is displayed.

Use the pull-out shower to rinse



- ☞ Tap the key "Confirm".
 - The information "Open door" appears.

- ☞ Open the cooking chamber door.
- ☞ Rinse the cooking chamber with the pull-out shower.
- ☞ Close the cooking chamber door.



- ☞ Tap the key "Confirm".

The cleaning process is finished,

- the display "Cleaning program" goes off,
- the display "Start screen" appears,
- carry out manual cleaning tasks, *refer to Page 87 Chapter 13.7!*



13.5 Cleaning the cooking chamber - automatically, with powdered cleaner (optional)

Safety information about powdered cleaner



- **WARNING! Caustic substances!** Wear safety goggles, protective gloves and protective clothing when handling powdered cleaner.
- Only use cleaning agents that are manufactured for these appliances and purposes and which have been recommended by the appliance manufacturer. Unsuitable cleaners may cause corrosion damage on stainless steel surfaces and damages to gaskets and components.
- The device manufacturer is not liable for any damage that has been caused as a result of improper cleaning or the use of incorrect cleaning agents.
- Observe the information on the packaging of the cleaning agent!
- Be sure to avoid skin or eye contact with the cleaning agent!
- Thoroughly rinse off any spilled cleaning agent with water!
- Do not mix the cleaning agent with other cleaners!
- Do not leave the cleaning agent for extended periods in the cooking chamber! Start the automatic cleaning immediately after filling in the cleaner.



- **WARNING! Danger of chemical burns!** Do not open the cooking chamber door during the cleaning process! If the cooking chamber door must be opened in exceptional cases, the automatic cleaning process must first be stopped (*see page 91 Chapter 13.9*).

13.5.1 Dosing quantities for powdered cleaner:

SALVIS Cleaner Powder, item number 885278

Portion quantity 35 g, e.g. using a bulk dosing bottle or measuring spoon.

Appliance type	Cleaning level 1:	Cleaning level 2:	Cleaning level 3:
623T	1 × 35 g	2 × 35 g	2 × 35 g
611T	1 × 35 g	2 × 35 g	2 × 35 g
1011T	1 × 35 g	2 × 35 g	3 × 35 g
611, 621QT	2 × 35 g	2 × 35 g	3 × 35 g
1011, 1021QT	2 × 35 g	2 × 35 g	3 × 35 g
2011, 2021QT	4 × 35 g	4 × 35 g	6 × 35 g

Do not overdose powdered cleaner; otherwise risk of damage of gaskets and components!

13.5.2 Starting the automatic cleaning process (powdered cleaner)



WARNING! Danger of chemical burns! Warning of possible injuries through escaping hot steam with caustic cleaning agents! Do not open the cooking chamber door during the automatic cleaning process!

- ☞ Preparing the appliance for cleaning the cooking chamber (see page 76 Chapter 13.3).
- ☞ We recommend opening the cooking chamber door for about 5 to 10 minutes to shorten the automatic cool-down process at very high temperatures (over 180°C).

1 Starting the automatic cleaning process



- ☞ Tap the "AutoClean" (automatic cleaning) key.
- The "Cleaning" window will be displayed.

2 Selecting the cleaning program



- ☞ Tap the desired cleaning level, e.g. level 3.
- The "Start" window will be displayed.

Key functions info:

The information for the cleaning time does not include the times for the cooling or heating process.



Cleaning level 1:
With little soiling - duration approx. 30 minutes



Cleaning level 2:
With medium soiling - duration approx. 75 minutes



Cleaning level 3:
With heavy soiling - duration approx. 90 minutes



Not active with powder cleaning feature/setting



Manual cleaning - duration approx. 20 minutes (*see page 78 Chapter 13.4*)



Rinsing the cooking chamber - duration approx. 12 minutes

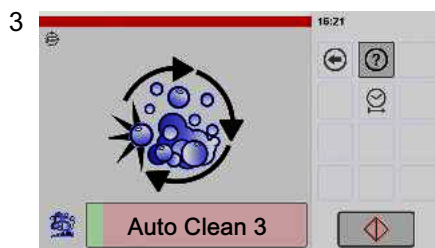

Starting the cleaning process



- ☞ Tap the "Start/Stop" key.
 - The symbol in the "Start/Stop" key changes from green to red.
 - A cooling or heating process takes place if the temperature in the cooking chamber is too high or too low.
 - Duration of the automatic cool-down until cleaning commences: At cooking chamber temperatures
 - 150°C = approx. 6 minutes,
 - 180°C = approx. 10 minutes,
 - 250°C = approx. 30 minutes.
 - After automatic temperature adjustment, the soaking process automatically starts.
 - The progress bar indicates the time progression of the process.

After the soaking process is finished, the message "Spray cleaner" appears.

Introduce the powdered cleaner.

- ☞ Open the cooking chamber door.
- ☞ Put on safety goggles, protective gloves and protective clothing.
- ☞ Distribute powder cleaner over the outlet screen (*doing see page 80 Chapter 13.5.1*).
- Do not spread the powdered cleaner in the cooking chamber!
- ☞ Close the cooking chamber door.
 - The information "Start cleaning process?" appears.



Confirmed the powdered cleaner dosing



- ☞ Tap the "Confirm" button.
 - The cleaning process runs.
 - The progress bar indicates the time progression of the process.

Once the cleaning process has completed,

- the display "Cleaning programme" disappears,
- the display "Start screen" appears,
- carry out manual cleaning tasks, *refer to Page 87 Chapter 13.7!*

13.6 Cleaning the cooking chamber - automatically, with liquid cleaner (optional)

Safety information on cleaning agents and rinse-aid



WARNING! Caustic substances! Wear safety goggles, protective gloves and protective clothing when handling cleaning and rinse-aid products.

- Use only cleaning agents and rinse-aids manufactured for these appliances and purposes and which have been recommended by the appliance manufacturer. Unsuitable cleaners may cause corrosion damage on stainless steel surfaces and damages to gaskets and components.
- The device manufacturer is not liable for any damage that has been caused as a result of improper cleaning or the use of incorrect cleaning agents.
- Observe the information on the packaging of the cleaning agent and rinse-aid!
- Be sure to avoid skin or eye contact with the cleaning agent and rinse-aid!
- Store the cleaning agent and rinse-aid only in the closed canister!
- Thoroughly rinse off any spilled cleaning agent or rinse-aid with water!
- Do not mix the cleaning agent or rinse-aid with other cleaners!



- **WARNING! Danger of chemical burns!** Do not open the cooking chamber door during the cleaning process! If the cooking chamber door must be opened in exceptional cases, the automatic cleaning process must first be stopped (see page 91 Chapter 13.9).

13.6.1 Connecting or replacing the cleaning agent and rinse-aid canisters

Only for appliances with "Liquid cleaning" feature.

Liquid cleaner: SALVIS Cleaner Fluid, canister 10 litres, item number ET100021

Liquid rinse-aid: SALVIS Rinser Fluid, canister 10 litres, item number ET100023

623T, 623, 611T, 611, 1011T

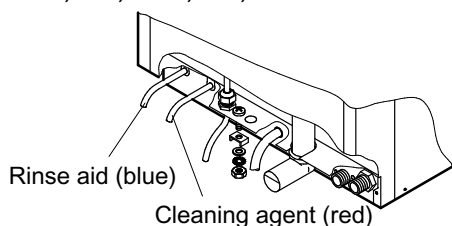

611QT, 1011QT

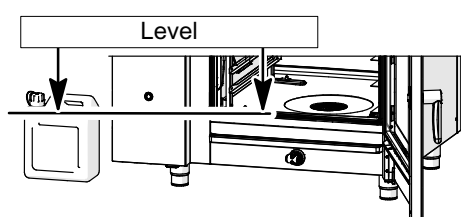
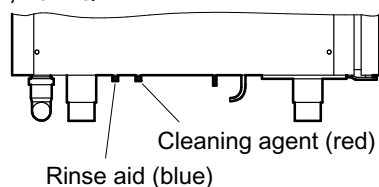

Connecting the hoses

- Note the information of the cleaning agent and rinse-aid manufacturer! Wear protective gloves, safety goggles and protective clothing.
- ☞ Do not place the canister above the level of the bottom of the cooking chamber, otherwise there is a risk of cleaning agent entering the appliance. The maximum head from the canister to the appliance connection is 1.50m, and the max. hose length is 10m.
- ☞ Unscrew the canister lid from the cleaner and rinse-aid and unscrew the respective pertaining canister union (red for cleaner, blue for rinse-aid).
- ☞ Check intake screens for blockage. Clean the intake screens if necessary.

13.6.2 Filling the suction hoses with cleaning agent and rinse-aid.

Only for appliances with "Liquid cleaning" feature.

- The lines and pumps must be completely filled with cleaning agent and rinse-aid. For this purpose, perform a suction procedure before the initial commissioning or after connecting the canisters.



Starting the suction process



- Tap the "AutoClean" (automatic cleaning) key.
- The "Cleaning" window will be displayed.



Selecting the suction process



- Tap the "Canister" key.
- The "Suction process" window will be displayed.



- Tap the "Start/Stop" key.
- The symbol in the "Start/Stop" key changes from green to red.
- The suction process runs.
- The pumping noises during the suction process can be clearly heard.
- Once the suction process has been completed, it is shut off automatically.
- Once the suction process is completed the symbol in the "Start/Stop" key changes from red to green.



Important: after the suction process, a rinsing or cleaning process must be carried out to remove any residue of cleaning agents from the interior of the cooking chamber.



The controls will not allow any cooking process until a rinsing or cleaning process has been completed!

Key functions info:



Filling the suction hoses after canister replacement



Rinsing the cooking chamber - duration approx. 12 minutes

13.6.3 Starting the automatic cleaning process (liquid cleaner)



WARNING! Danger of chemical burns! Warning of possible injuries through escaping hot steam with caustic cleaning agents! Do not open the cooking chamber door during the automatic cleaning process!

- ☞ Preparing the appliance for cleaning the cooking chamber (see page 76 Chapter 13.3).
- ☞ We recommend opening the cooking chamber door for about 5 to 10 minutes to shorten the automatic cool-down process at very high temperatures (over 180°C).



Starting the automatic cleaning process



- ☞ Tap the "AutoClean" (automatic cleaning) key.
- The "Cleaning" window will be displayed.



Selecting the cleaning program



- ☞ Tap the desired cleaning level, e.g. level 3.
- The "Start" window will be displayed.

-> If cleaning should be immediately started, continue with Figure 3.

-> If cleaning should be automatically started at a specified time, refer to Applying the start time from Figure 4 and 5.

Key functions info:

The information for the cleaning time does not include the times for the cooling or heating process.



Cleaning level 1:
With little soiling - duration approx. 30 minutes



Cleaning level 2:
With medium soiling - duration approx. 75 minutes



Cleaning level 3:
With heavy soiling - duration approx. 90 minutes



Filling the suction hoses after canister replacement



Manual cleaning - duration approx. 20 minutes (see page 78 Chapter 13.4)



Rinsing the cooking chamber - duration approx. 12 minutes (rinsing takes place with rinse-aid if a rinse-aid canister is connected)



Start time

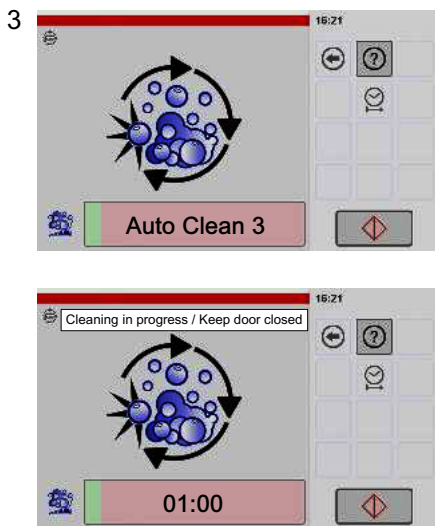

Starting the cleaning process

- ☞ Tap the "Start/Stop" key.
 - The symbol in the "Start/Stop" key changes from green to red.
 - A cooling or heating process takes place if the temperature in the cooking chamber is too high or too low.
 - Duration of the automatic cool-down until cleaning commences: At cooking chamber temperatures
 - 150°C = approx. 6 Minuten,
 - 180°C = approx. 10 Minuten,
 - 250°C = approx. 30 Minuten.
 - Cleaning starts automatically following the automatic temperature adjustment.
 - The progress bar indicates the time progression of the process.

Once the cleaning process has completed,

- the display "Cleaning programme" disappears,
- the display "Start screen" appears,
- carry out manual cleaning tasks, *refer to Page 87 Chapter 13.7!*

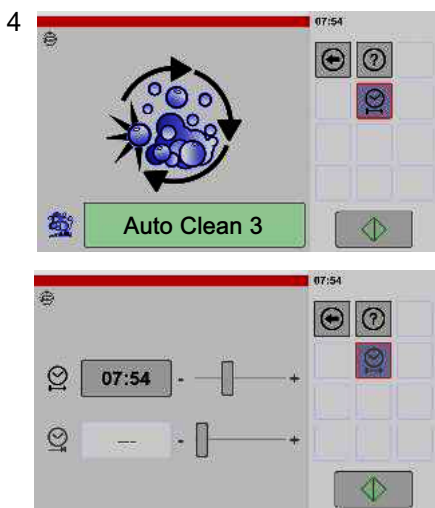

Display window Start time

If no start time is required, continue with Figure 3!

- ☞ Tap the key "Start time".
 - The key is shaded dark grey and framed.
- ☞ Tap the key "Start/Stop".
 - The Start time window is displayed.
- ☞ Tap on the display "Time".
 - The numeric keypad is displayed.

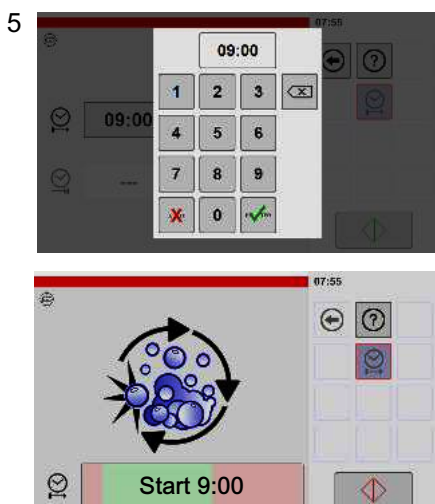

Enter the start time

- ☞ Set the start time using the numeric keypad.
- ☞ Tap the key "Enter".
 - The Cleaning window is displayed.

- The time for starting cleaning is displayed.
- When reaching the time, the cleaning automatically starts.

Description of the cleaning process, refer to Figure 3 in this chapter!

13.7 After completion of automatic cleaning

- ☞ Switch the appliance off.
- ☞ Remove possibly remaining soiling, for example, on the removable racks or rack trolley, with a cleaning brush and cleaning agent or repeat automatic cleaning.
- ☞ Cleaning the cooking chamber door and seal (*see page 88 Chapter 13.7.1*).
- ☞ Clean the outlet screen.
- ☞ Flush out the water drain to flush remaining dirty water from the drain. Use the pull-out shower and spray into the outlet screen.
- ☞ Thoroughly rinse the inside of the cooking chamber and the area behind the air baffle with the pull-out shower.
- ☞ Wipe out the residual water in the cooking chamber.

Dry the cooking chamber

- ☞ Dry any spots that are still wet.
- ☞ Lift the removable racks and dry the bearing surface, otherwise a risk of corrosion at the contact points!
- ☞ As needed: Switch on the Hot Air cooking method - duration approx. 10 minutes, humidity 0%, temperature approx. 130°C.
- ☞ Switch off the unit.
- ☞ Leave the cooking chamber door open to allow it to dry completely.

Protect cooking chamber and installation parts against corrosion

Stainless steel surfaces and installation parts in the cooking chamber are attacked through use. Therefore, treat stainless steel surfaces and installation parts in the cooking chamber using cooking oil or cream cleaner at intervals of approx 1-2 weeks.

SALVIS Non-Stick, Protection and Care (care emulsion) 0.5 l - item no. ET100060

- ☞ Spray the cooking chamber, removable racks and air baffles using cooking oil or cream cleaner.
- ☞ Use a lint-free cloth and uniformly distribute the cooking oil/cream cleaner.
 - No drops must form, otherwise blotches form.
 - Leave no puddles of cooking oil or cream cleaner.
 - No cooking oil or cream cleaner must flow into the drain of the cooking chamber.
 - Finely distribute the cooking oil/cream cleaner, otherwise heavy development of smoke during hot-air mode is possible.

13.7.1 Cleaning the glazing, cooking chamber door and seal

Cleaning the glazing surfaces

- ☞ Do not use any abrasive and acid-containing cleaning agents.
- ☞ Clean the glazing with grease-dissolving cleaning agent and a soft cleaning cloth.

Cleaning the control and display panel, see page 91 section 13.7.6

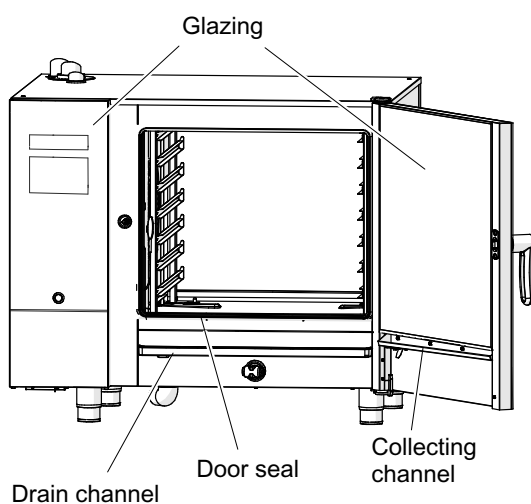

Cleaning the door seal

Food greases and cleaning agents attack the seal material and accelerate wear. Clean the door seal therefore each day.

- ☞ Clean the door seal with grease-dissolving cleaning agent.
- ☞ Thoroughly dry the door seal.

Cleaning the drain channel and collecting channel.

- ☞ Clean drain channel and collecting channel.
- ☞ Remove possible clogging at the drain openings.

After cleaning

- ☞ Do not close the cooking chamber door; keep it a crack open.
- The residual moisture can escape from the cooking chamber and the door seal is free from pressure.

13.7.2 Cleaning the grease filter (optional)

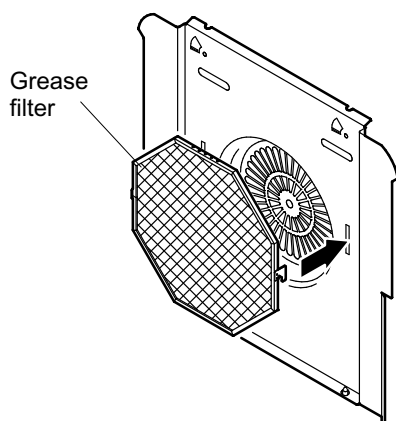

- Remove the grease filter from the cooking chamber before automatic cleaning and clean it separately.
- ☞ If the grease filter is heavily soiled, cleaned it in the dish washer or by hand.
- ☞ After cleaning thoroughly flush the grease filter with clear water and dry it.

13.7.3 Cleaning the cooking chamber behind the air baffle.

- ☞ Switch the appliance off.
- ☞ Switch off the mains switch and secure it against being switched back on.



- The air baffle may not be dismantled or mounted while the ventilator is still running!
- The device may not be operated without air baffle!

Air baffle (at rear of cooking chamber)

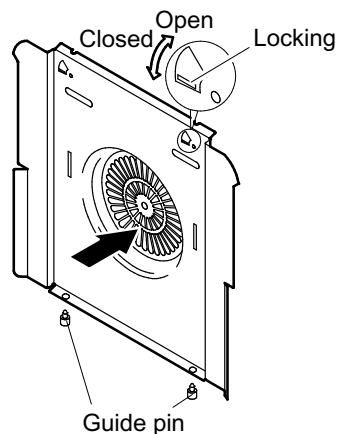

Removing the air baffle Type 623T, 611T, 1011T

- ☞ Unlock the two locks with a screwdriver by turning them to the right.
- ☞ Unhook the air baffle from the lower guide pins and remove it.
- ☞ Remove any possibly remaining soiling behind the air baffle or on the removable racks with cleaning agent and a cleaning brush.

Air baffle (at left in cooking chamber)

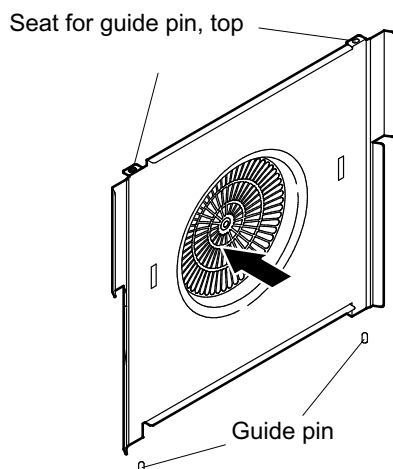

Removal of the air baffle Type 611, 621QT, 1011, 1021QT

- ☞ Lift the air baffle and unhook it from the guide pins; do not cock (risk of bending the guide pins).
- ☞ Lower the air baffle and remove.
- ☞ Remove any possibly remaining soiling behind the air baffle or on the removable racks with cleaning agent and a cleaning brush.

Inserting the air baffles

Inserting the air baffles and grease filter, see page 14 section 5.1.3

Air baffle (at left in cooking chamber)

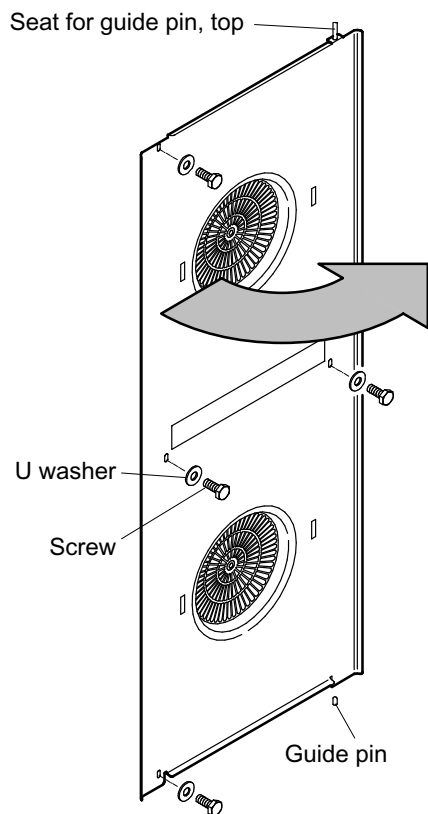

Swivelling the air baffle
Type 2011, 2021QT

- ☞ Remove four screws and U washers.
- ☞ Swivel in air baffle.

Inserting the air baffles

Inserting the air baffles and grease filter, see page 14 section 5.1.3

13.7.4 Clean air filter

Type 623 T, 611 T, 1011 T

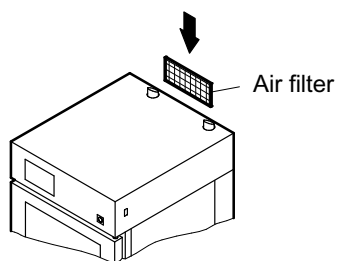

- The air filter must be cleaned at least once a month, depending on the amount of soiling.
- ☞ Pull out the air filter toward the front and clean, e.g. in the dish washer.
- The air filter may only be inserted when dry.

Type 611, 621, 1011, 1021QT
2011, 2021QT

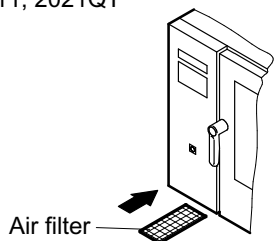

13.7.5 Clean stainless steel surfaces

- ☞ Clean stainless steel surfaces with grease-dissolving cleaner or a special stainless steel cleaner.
- ☞ Dry cleaned parts and surfaces with a soft cloth.
- ☞ Restoring operational readiness (*refer to Page 14, Chapter 5.1*).

13.7.6 Cleaning the control/display panel and the key "On/Off"



- The control/display panel and the "On/Off" button have to be free of any detergent residues after cleaning.
- The mixture of detergent residues and precipitating humidity affect the reaction of the control/display panel.
- Remove residual cleaning agent from the control/display panel only when switched off.

☞ Then clean the control/display panel with warm water and cotton cloths.

☞ As required, use special cleaning agent manufactured for Touchscreens (Touchpad) and that prevents condensation of steam.

13.8 Decalcifying the cooking chamber

No scale may develop in the cooking chamber if the appliance has been properly connected to a water softening system. If scale still forms, the water softening system must be inspected and the cooking chamber decalcified.

☞ Use the decalcifying agent according to the manufacturer's instructions in the cooking chamber.

13.9 Cancelling automatic cleaning

Automatic cleaning should be cancelled only in exceptional situations!

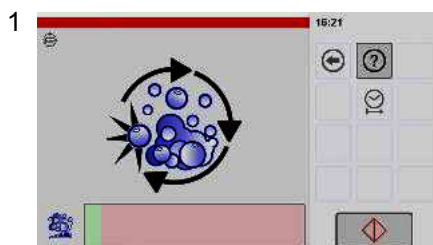

☞ Tap the "Start/Stop" key.

- Automatic cleaning is stopped.
- The cleaning system still contains cleaning agent after stopping the cleaning process. A cooking process can therefore only be started after an automatic rinse process was first performed.
- If there is a power cut during automatic cleaning, a rinsing operation will be required.



Rinsing process after cancellation

A rinsing process must be performed if the automatic cleaning of the cooking chamber was interrupted. Duration approx. 15 to 20 minutes (rinsing process takes place with rinse-aid if a rinse-aid canister is connected) It is not possible to cancel rinsing by tapping the "Start/Stop" key during the process.

Starting the rinse process, refer to Page 85 Chapter 13.6.3 (Figure 2)

13.10 Cleaning of the condensate cover, air filter (optional)

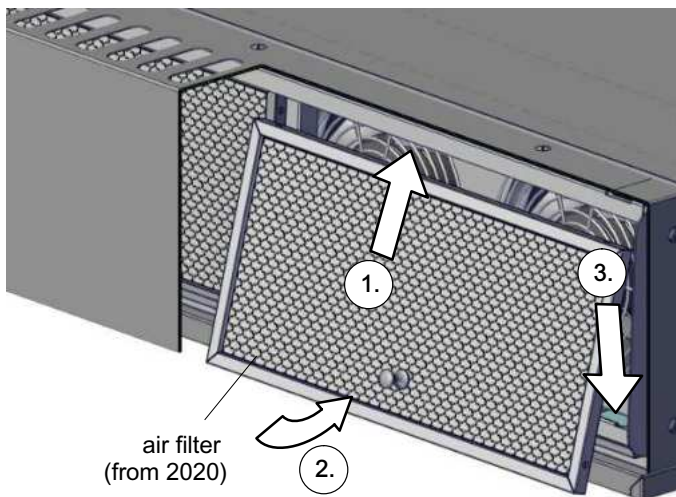

Important! Condensation covers must be cleaned regularly!

- Depending of the degree of contamination, the condensation cover (optional) should be cleaned by an authorised customer service technician at least once a year!
- The air filter must be cleaned at least once a month, depending on the amount of soiling.
- ☞ Remove air filter and clean, e.g. in the dish washer.
- The air filter may only be inserted when dry.

14. Errors and remedies

Check any faults in the appliance against the following table:

Fault	Possible cause	Remedy
No response appears on the display screen after switching on the appliance.	Main switch in building not turned on before switching on the appliance. There is no power supply at all. Mains fuse has tripped.	Turn on main switch. Inform electricity the electricity supply company. Possible faults on the appliance must be checked by an authorised Customer Service agent. Reset the circuit breaker.
The spray hose seal is broken or faulty.	Leaks, lime scale deposits, material fatigue.	In order to continue operation with the appliance, the function pull-out shower can be deactivated (refer to Page 67, Figure 16). Contact your customer service representative.
The optional condensate cover no longer functions properly.	The air vents are blocked. The inside of the condenser cover is contaminated.	Clean the supply and exhaust air apertures. Clean air filter (from 2020). Contact the authorized customer service.
Corrosion in the cooking chamber	Poor quality of water. Incorrect cleaner. Residual limescale, grease, starch and protein not completely removed. Iron particles in the supply water.	Filter the water. Observe the installation instructions! Only use cleaning agents released by the appliance manufacturer! Thoroughly clean the cooking chamber. Not even the smallest particle of residue must be on the surface of the cooking chamber. Corrosion can form under this residue. Remove all water supply pipes on site made from iron/stainless steel.

Fault	Possible cause	Remedy
Fault report: No. 2003, 2004	Communication fault in the control.	Switch off the appliance for 1 minute. Contact the authorized Customer Service if the fault recurs.
Fault report: No. 3001	The safety temperature limiter has cut out because of overheating. The appliance was transported during freezing temperatures. Frozen product was stored in the cooking chamber. The safety temperature limiter has cut out because of cooling below -5°C .	Open the cooking chamber door, allow the appliance to cool. Turn the appliance off and on. Contact the authorized Customer Service if the fault recurs. Set up the appliance in a warm dry room. Open the cooking chamber door. When the safety temperature limiter has warmed up above $+5^{\circ}\text{C}$, it will automatically switch back on.
Fault report: No. 3003, 3004	Temperature sensor in the cooking chamber interrupted or short-circuited.	Turn the appliance off and on. Contact the authorized Customer Service if the fault recurs. Type 2011, 2021: If only the upper or lower area of the cooking chamber is affected, the appliance can continue to be operated with the functional area.
Fault report: No. 3005	Overtemperature in cooking chamber	Switch off the unit. Open the cooking chamber door and allow the cooking chamber to cool. Contact the authorized Customer Service if the fault recurs.
Fault report: No. 3006, 5001	Overtemperature in electric compartment	Allow the appliance to cool. Clear the vent openings. Clean the air filter. Supply adequate cool air. Contact the authorized Customer Service if the fault recurs.
Fault display: No. 4001, 4002, 4085	Water pressure insufficient	Open the water tap. Check the flow pressure. Drawing water from several points can cause the flow pressure to drop too far. Ensure sufficient flow pressure.
Fault report: No. 4003	Overtemperature in water drain	Appliance with water connection: Open the water tap. Appliance without water connection: Pour at least 5 litres of water into the outlet screen in the cooking chamber. Contact the authorized Customer Service if the fault recurs.
Fault report: Nos. 4042 to 4055	Sensor interrupted or short-circuited.	Turn the appliance off and on. Contact the authorized Customer Service if the fault recurs. Type 2011, 2021: If only the upper or lower area of the cooking chamber is affected, the appliance can continue to be operated with the functional area.

Fault	Possible cause	Remedy
After startup, a message appears informing you that servicing is required.	The specified fan motor runtime has been reached.	Notify your authorized customer service representative. Seals are subject to wear. If servicing is not carried out on the motor seal, water may escape. This may result in consequential damage to the appliance.
Fault report: Miscellaneous	Miscellaneous	Note the fault number. Turn the appliance off and on. If the fault continues to occur, contact authorised Customer Service and inform them of the fault number.

If you cannot remedy the fault,

- turn off the appliance and disconnect from the mains;
- do not open the housing but
- notify the authorised Customer Service and tell them the fault number.

Repairs may only be performed by the authorised Customer Service!

15. Service



DANGER! Electrical voltage! Risk of electric shock that may result in serious injury or death! Installation, service and repair tasks may only be carried out by authorised Customer Service. During installation, service and repair work, the appliance must be disconnected from the mains and secured to prevent it being switched on again!

- Have the appliance inspected and serviced on a regular basis by the authorised Customer Service. Maintenance tasks are, e.g. safety, function and leak checks.
- Have the water softening system regularly inspected and serviced.
- Have the appliance decalcified, if necessary.
- Depending of the degree of contamination, the condensation cover (optional) should be cleaned by an authorised customer service technician at least once a year!
- Use only genuine accessories and spare parts.
- We recommend entering into a maintenance contract with the authorized Customer Service.

16. Disposal of end-of-life appliances

- Before dismantling, switch off the appliance at the mains and safeguard it against being switched back on. Then disconnect the mains cable from the mains socket and from the appliance.
- To prevent accident from being trapped, the door closing mechanism must be removed when dismantling and disposing of the appliance.
- Old appliances are not worthless rubbish. Valuable raw materials can be recovered as a result of environmentally friendly waste disposal.
- Observe the relevant legal requirements when disposing of the appliance.
- Commercial electrical appliances must not enter the municipal waste disposal system or be disposed of with household waste.



17. Declaration of Conformity

This declaration relates only to the appliances in the condition in which they were placed on the market. The declaration is invalidated if the product has been converted or modified without consent.

EU-Declaration of Conformity	UK-Declaration of Conformity
<p>We hereby declare that the machines identified below comply with the appropriate health and safety requirements of the Machine Directive 2006/42/EG on the basis of their design and construction and in the versions placed on the market by us.</p> <p>The machines also comply with the requirements of the directive 2014/35/EU for electrical machines, the 2014/30/EU for electro-magnetic compatibility, the RoHS Directives 2011/65/EU..</p>	<p>We hereby declare that the machines identified below comply with the appropriate health and safety requirements of the Supply of Machinery (Safety) Regulations 2008 on the basis of their design and construction and in the versions placed on the market by us.</p> <p>The machines also comply with the requirements of the Electrical Equipment (Safety) Regulations 2016, the Electromagnetic Compatibility Regulations 2016 and the RoHS Regulations 2012.</p>

Machine types

Circulating hot air steamers / combi-steamers

Applied standards

EU	UK
DIN EN 60335-1, DIN EN 60335-2-42, DIN EN 60335-2-102, DIN EN 203-1, DIN EN 203-2-2, DIN EN 203-2-3, NTA 8837, DIN EN 55014-1, DIN EN 55014-2, DIN EN 1717	BS EN 60335-1 BS EN 60335-2-42 BS EN IEC 55014-1 BS EN IEC 55014-2 BS EN 61000-4-2 BS EN IEC 61000-4-3 BS EN 61000-4-4 BS EN 61000-4-6 BS EN 62233 BS EN 1717

Authorised representative for documentation:

SERVATOR ServiceLine GmbH, Thomas Schmalz, Lindenweg 36-42, 97999 Igersheim, Germany

18. Software declaration

The software used in this appliance contains a "General Public License" (GNU). The license certificate can be found in its original English version at the following web address: "<http://www.gnu.org/licenses/gpl.html>". This free software does not include the free distribution of our libraries.

878970 / 7.11 / 12.24 / V27g

SALVIS AG
Nordstrasse 15
CH-4665 Oftringen
Tel. +41 (0)62 788 18 18
Fax. +41 (0)62 788 18 98
Internet: www.salvis.ch
E-Mail: info@salvis.ch

